

**SOUTH DAKOTA DEPARTMENT OF TRANSPORTATION
BRIDGE VERTICAL CLEARANCE LIST - 04/25/2024**

Secondary Structure	Structure Controlling Height	Hwy Number	MRM	Location	Structure Type	Maximum Permit Clearance	By-pass ?
Interstate Hwys							
	64-158-399	I-29 NBL	0.98	Dakota Dunes Exit Interchange # 1	Interchange	16' 3"	Yes
		I-29 NBL	1.68	.80 mi south of N Sioux City Interchange	Cantilever Sign Bridge	18' 5"	Yes
		I-29 NBL	2.25	.25 mi south of N Sioux City Interchange	Cantilever Sign Bridge	18' 4"	Yes
	64-149-367	I-29 NBL	4.35	McCook Lake Exit Interchange # 4	Interchange	16' 2"	Yes
	64-140-355	I-29 NBL	5.88	Horse Track Road 1.5 mi North Interchange # 4	Underpass	16' 4"	No
	64-120-336	I-29 NBL	8.76	County Road 0.5 mi SE Interchange # 9	Underpass	16' 3"	No
	64-115-330	I-29 NBL	9.51	Jefferson Exit (old SD 105) Interchange # 9	Interchange	16' 4"	Yes
	64-100-315	I-29 NBL	11.67	County Road # 6285 2 mi NW Interchange # 9	Underpass	16' 3"	No
	64-080-296	I-29 NBL	14.53	County Road 1.3 mi SE Interchange # 15	Underpass	16' 5"	No
	64-070-287	I-29 NBL	15.79	East Elk Point Exit (I-29 Loop) Interchange # 15	Interchange	16' 5"	Yes
	64-050-250	I-29 NBL	20.49	County Road 2 mi North Interchange # 18	Underpass	17' 9"	No
	64-020-220	I-29 NBL	24.72	County Road 2 mi South Interchange # 26	Underpass	17' 9"	No
	64-008-205	I-29 NBL	26.71	Junction City Exit (SD 50W) Interchange # 26	Interchange	16' 6"	Yes
	64-006-160	I-29 NBL	31.28	Spink Exit (SD 48) Interchange # 31	Interchange	16' 5"	Yes
	64-006-120	I-29 NBL	35.31	County Road 4 mi North Interchange # 31	Underpass	16' 6"	No

The vertical clearance is the minimum clearance measured above the through driving lanes. The vertical clearance above the shoulders may be less than the clearance shown. The vertical clearance outside the driving lane edgelines may be less than the clearance shown. **The vertical clearances in this list are provided for informational purposes only. It is a permit holders responsibility to verify the clearances on the route traveled.**

	64-006-100	I-29 NBL	37.32	County Road 1 mi South Interchange # 38	Underpass	16' 9"	No
--	------------	----------	-------	---	-----------	--------	----

Secondary Structure	Structure Controlling Height	Hwy Number	MRM	Location	Structure Type	Maximum Permit Clearance	By-pass ?
	64-006-090	I-29 NBL	38.32	Hub City Exit (County Road #6370) Interchange # 38	Interchange	16' 2"	Yes
	64-006-030	I-29 NBL	44.30	County Road 3 mi South Interchange # 47	Underpass	16' 9"	No
	64-006-010	I-29 NBL	46.31	County Road 1 mi South Interchange # 47	Underpass	16' 10"	No
	64-006-000	I-29 NBL	47.31	Beresford Exit (SD 46) Interchange # 47	Interchange	17' 0"	Yes
	42-065-260	I-29 NBL	50.31	County Road # 6116 Interchange # 50	Interchange	15' 9"	Yes
	42-065-230	I-29 NBL	53.32	County Road # 6102 Interchange # 53	Interchange	17' 11"	Yes
	42-065-200	I-29 NBL	56.33	County Road # 6382 Interchange # 56	Interchange	15' 11"	Yes
	42-065-170	I-29 NBL	59.34	Davis Exit (US 18W) Interchange # 59	Interchange	15' 11"	Yes
	42-065-140	I-29 NBL	62.34	Canton Exit (US 18E) Interchange # 62	Interchange	17' 2"	Yes
	42-065-130	I-29 NBL	63.34	County Road 1 mi North Interchange # 62	Underpass	16' 3"	No
	42-065-120	I-29 NBL	64.34	Worthing Exit (SD 44) Interchange # 64	Interchange	16' 6"	Yes
	42-065-100	I-29 NBL	66.34	County Road 2 mi North Interchange # 64	Underpass	16' 3"	No
	42-065-080	I-29 NBL	68.35	County Road Interchange # 68	Interchange	16' 3"	Yes
	42-065-050	I-29 NBL	71.36	S. Tea Exit (County Road #6378) Interchange # 71	Interchange	16' 5"	Yes
		I-29 NBL	74.15	0.77 Miles North of Tea Interchange	Sign Bridge	18' 4"	No
		I-29 NBL	74.66	1.3 Miles North of Tea Interchange	Sign Bridge	18' 2"	No
		I-29 NBL	75.16	1.8 Miles North of Tea Interchange	Sign Bridge	18' 4"	No
	50-172-240	I-29 NBL	76.19	57th Street mi South Interchange # 77	Underpass	17' 1"	No
	50-173-235	I-29 NBL	76.72	49th Street 0.5 mi South Interchange # 77	Underpass	16' 3"	No
	50-175-230	I-29 NBL	77.26	41st Street Exit Interchange # 77	Interchange	16' 4"	Yes
		I-29 NBL	77.62	.33 mi North of 41st Street Interchange	Cantilever Sign Bridge	19' 0"	Yes

Secondary Structure	Structure Controlling Height	Hwy Number	MRM	Location	Structure Type	Maximum Permit Clearance	By-pass ?
		I-29 NBL	77.86	.60 mi North of 41st Street Interchange	Cantilever Sign Bridge	19' 0"	Yes
	50-175-222	I-29 NBL	78.12	26th Street Exit Interchange # 78	Interchange	16' 10"	Yes
		I-29 NBL	78.40	.25 mi North of 26th Street Interchange	Cantilever Sign Bridge	18' 10"	Yes
		I-29 NBL	78.88	.4 mi South of 12th Street Interchange	Sign Bridge	18' 8"	No
		I-29 NBL	79.71	.45 mi North of 12th Street Interchange	Cantilever Sign Bridge	19' 5"	Yes
		I-29 NBL	79.76	.5 mi North of 12th Street Interchange	Sign Bridge	19' 2"	No
	50-177-196	I-29 NBL	80.82	Pedestrian Bridge 2.5 mi S of SD 38E Interchange	Ped Bridge	18' 0"	No
	50-178-191	I-29 NBL	81.32	2.0 mi S of SD 38E Interchange	Underpass	17' 5"	No
		I-29 NBL	81.82	.6 mi South of Benson Road Interchange	Sign Bridge	18' 9"	No
		I-29 NBL	82.09	South of Exit 82	Sign Bridge	20' 1"	No
		I-29 NBL	82.76	.35 MI North of Benson Road Interchange	Cantilever Sign Bridge	18' 7"	Yes
		I-29 NBL	83.07	.3 mi South of West 60th Street Interchange	Sign Bridge	19' 6"	No
	50-180-170	I-29 NBL	83.38	SD 38 / 60th Street Interchange # 83	Interchange	17' 6"	Yes
		I-29 NBL	83.94	.2 mi South of I-90 Interchange	Sign Bridge	17' 5"	No
		I-29 NBL	84.10	0.05 mi South of I-90 Interchange	Cantilever Sign Bridge	17' 0"	Yes
50-180-163	50-180-162	I-29 NBL	84.17	I-90 Exit Interchange # 84	Interchange	16' 6"	No
	50-180-140	I-29 NBL	86.40	Renner Exit (County Road #6364) Interchange # 86	Interchange	15' 11"	Yes
	50-177-130	I-29 NBL	87.45	County Road 1 mi North Interchange # 86	Underpass	15' 8"	No
	50-175-040	I-29 NBL	96.48	County Road 2 mi North Interchange # 94	Underpass	15' 9"	No
	50-175-020	I-29 NBL	98.48	Dell Rapids Exit (SD 115) Interchange # 98	Interchange	16' 7"	Yes
	51-065-210	I-29 NBL	103.81	County Road 1 mi South Interchange # 104	Underpass	16' 1"	No

Secondary Structure	Structure Controlling Height	Hwy Number	MRM	Location	Structure Type	Maximum Permit Clearance	By-pass ?
	51-065-200	I-29 NBL	104.81	Trent Exit (County Road #6334) Interchange # 104	Interchange	16' 3"	Yes
	51-065-150	I-29 NBL	109.83	Colman Exit (SD 34) Interchange # 109	Interchange	16' 3"	Yes
	51-066-100	I-29 NBL	114.83	Flandreau Exit (SD 32) Interchange # 114	Interchange	16' 11"	Yes
	51-065-050	I-29 NBL	119.81	County Road 5 mi North Interchange # 114	Underpass	16' 10"	No
	06-185-230	I-29 NBL	125.80	County Road 4 mi North Interchange # 121	Underpass	16' 8"	No
	06-185-210	I-29 NBL	127.81	SD 324 Exit Interchange # 127	Interchange	16' 6"	Yes
	06-185-190	I-29 NBL	129.80	County Road 2 mi North Interchange # 127	Underpass	16' 5"	No
	06-185-180	I-29 NBL	130.81	20th St. 2.0 mi S of US 14 Exit 132 - New Interchange	Interchange	17' 1"	No
	06-185-190	I-29 NBL	129.80	County Road 2 mi North Interchange # 127	Underpass	16' 5"	No
	06-185-159	I-29 NBL	132.81	US 14 / 6th Street Exit Interchange # 132	Interchange	17' 0"	Yes
		I-29 NBL	133.23	Brookings Between US 14 Exit 132 and US 14B Exit 133	Cantilver Sign Bridge	17' 4"	Yes
		I-29 NBL	133.52	Brookings Between US 14 Exit 132 and US 14B Exit 133	Cantilver Sign Bridge	17' 10"	Yes
	06-185-150	I-29 NBL	133.79	US 14B / 18th Street Interchange # 133	Interchange	16' 4"	Yes
	06-185-130	I-29 NBL	135.81	County Road 2 mi North Interchange # 133	Underpass	16' 5"	No
	06-185-110	I-29 NBL	137.79	County Road 4 mi North Interchange # 133	Underpass	16' 2"	No
	06-185-080	I-29 NBL	140.78	White Exit (SD 30) Interchange # 140	Interchange	16' 4"	Yes
	20-061-280	I-29 NBL	150.88	Toronto Exit (SD 28) Interchange # 140	Interchange	16' 5"	Yes
	29-280-020	I-29 NBL	167.40	County Road CR-464 / 464th Ave 2.8 mi NW Interchange # 164	Underpass	16' 5"	No
	15-240-220	I-29 NBL	173.02	County Road 5 mi SE Interchange # 177	Underpass	16' 6"	No
	15-215-150	I-29 NBL	180.95	US 81 Exit Interchange # 180	Interchange	16' 7"	Yes

Secondary Structure	Structure Controlling Height	Hwy Number	MRM	Location	Structure Type	Maximum Permit Clearance	By-pass ?
	15-215-120	I-29 NBL	183.94	County Road CR-8 / 166th St 3 mi North Interchange # 180	Underpass	17' 5"	No
	15-215-070	I-29 NBL	189.00	County Road CR-4 / 161st St 3 mi North Interchange # 185	Underpass	17' 5"	No
	15-215-030	I-29 NBL	193.03	South Shore Exit (SD 20) Interchange # 193	Interchange	16' 11"	Yes
	55-085-440	I-29 NBL	206.08	County Road CR-27 / 144th St 5 mi North Interchange # 201	Underpass	16' 5"	No
	55-085-429	I-29 NBL	207.30	Summit Exit (US 12) Interchange # 207	Interchange	17' 2"	Yes
	55-100-367	I-29 NBL	213.88	Wilmot Exit (SD 15) Interchange # 213	Interchange	16' 6"	Yes
	55-115-330	I-29 NBL	218.00	County Road 4 mi North Interchange # 213	Underpass	16' 4"	No
	55-115-290	I-29 NBL	222.02	County Road 2 mi South Interchange # 224	Underpass	16' 4"	No
	55-115-220	I-29 NBL	229.03	County Road 3 mi South Interchange # 232	Underpass	16' 7"	No
	55-116-190	I-29 NBL	232.08	Sisseton Exit (SD 10) Interchange # 232	Interchange	16' 7"	Yes
	55-124-170	I-29 NBL	234.11	County Road 2 mi North Interchange # 232	Underpass	16' 8"	No
	55-144-130	I-29 NBL	238.51	County Road 6.5 mi NE Interchange # 232	Underpass	16' 7"	No
	55-175-040	I-29 NBL	248.54	County Road 104th St 2 mi North Interchange # 246	Underpass	16' 6"	No
	55-175-040	I-29 SBL	248.54	County Road 2 mi North Interchange # 246	Underpass	16' 6"	No
	55-144-130	I-29 SBL	238.51	County Road 6.5 mi NE Interchange # 232	Underpass	16' 5"	No
		I-29 SBL	235.77	WIM Scales near Sisseton Port of Entry	Cantilever Mast Arm	18' 11"	No
		I-29 SBL	235.63	WIM Scales near Sisseton Port of Entry	Cantilever Mast Arm	19' 2"	No
	55-124-170	I-29 SBL	234.11	County Road 2 mi North Interchange # 232	Underpass	16' 7"	No
	55-116-190	I-29 SBL	232.08	Sisseton Exit (SD 10) Interchange # 232	Interchange	16' 10"	Yes
	55-115-220	I-29 SBL	229.03	County Road 3 mi South Interchange #232	Underpass	16' 6"	No
	55-115-290	I-29 SBL	222.02	County Road 2 mi South Interchange # 224	Underpass	16' 8"	No

Secondary Structure	Structure Controlling Height	Hwy Number	MRM	Location	Structure Type	Maximum Permit Clearance	By-pass ?
	55-115-330	I-29 SBL	218.00	County Road 4 mi North Interchange # 213	Underpass	16' 7"	No
	55-100-367	I-29 SBL	213.88	Wilmot Exit (SD 15) Interchange # 213	Interchange	16' 6"	Yes
	55-085-429	I-29 SBL	207.30	Summit Exit (US 12) Interchange # 207	Interchange	16' 4"	Yes
	55-085-440	I-29 SBL	206.08	County Road 5 mi North Interchange # 201	Underpass	16' 3"	No
	15-215-030	I-29 SBL	193.03	South Shore Exit (SD 20) Interchange # 193	Interchange	16' 5"	Yes
	15-215-070	I-29 SBL	189.00	County Road 3 mi North Interchange # 185	Underpass	16' 4"	No
	15-215-120	I-29 SBL	183.94	County Road 3 mi North Interchange # 180	Underpass	16' 5"	No
	15-215-150	I-29 SBL	180.95	US 81 Exit Interchange # 180	Interchange	16' 3"	Yes
	15-240-220	I-29 SBL	173.02	County Road CR-20 / 176th St 5 mi SE Interchange # 177	Underpass	16' 9"	No
	29-280-020	I-29 SBL	167.40	County Road 2.8 mi NW Interchange # 164	Underpass	16' 5"	No
	20-061-280	I-29 SBL	150.88	Toronto Exit (SD 28) Interchange # 150	Interchange	16' 10"	Yes
	06-185-080	I-29 SBL	140.78	White Exit (SD 30) Interchange # 140	Interchange	16' 2"	Yes
	06-185-110	I-29 SBL	137.79	County Road 4 mi North Interchange # 133	Underpass	16' 7"	No
	06-185-130	I-29 SBL	135.81	County Road 2 mi North Interchange # 133	Underpass	17' 2"	No
	06-185-150	I-29 SBL	133.79	US 14 B / 18th Street Interchange # 133	Interchange	16' 8"	Yes
		I-29 SBL	133.40	Brookings Between US 14 Exit 132 and US 14B Exit 133	Cantilver Sign Bridge	18' 8"	Yes
		I-29 SBL	133.14	Brookings Between US 14 Exit 132 and US 14B Exit 133	Cantilver Sign Bridge	19' 0"	Yes
	06-185-159	I-29 SBL	132.81	US 14 / 6th Street Exit Interchange # 132	Interchange	17' 7"	Yes
	06-185-180	I-29 SBL	130.81	20th St. 2.0 mi S of US 14 Exit 132 - New Interchange	Interchange	17' 2"	No
	06-185-190	I-29 SBL	129.80	County Road 2 mi North Interchange # 127	Underpass	16' 6"	No
	06-185-210	I-29 SBL	127.81	SD 324 Exit Interchange # 127	Interchange	16' 7"	Yes

Secondary Structure	Structure Controlling Height	Hwy Number	MRM	Location	Structure Type	Maximum Permit Clearance	By-pass ?
	06-185-230	I-29 SBL	125.80	County Road 4 mi North Interchange # 121	Underpass	16' 9"	No
	51-065-050	I-29 SBL	119.81	County Road 5 mi North Interchange # 114	Underpass	16' 4"	No
	51-066-100	I-29 SBL	114.83	Flandreau Exit (SD 32) Interchange # 114	Interchange	16' 7"	Yes
	51-065-150	I-29 SBL	109.83	Colman Exit (SD 34) Interchange # 109	Interchange	16' 1"	Yes
	51-065-200	I-29 SBL	104.81	Trent Exit (County Road #6334) Interchange # 104	Interchange	16' 1"	Yes
	51-065-210	I-29 SBL	103.81	County Road 1 mi South Interchange # 104	Underpass	16' 3"	No
	50-175-020	I-29 SBL	98.48	Dell Rapids Exit (SD 115) Interchange # 98	Interchange	17' 8"	Yes
	50-175-040	I-29 SBL	96.48	County Road 2 mi North Interchange # 94	Underpass	17' 6"	No
	50-177-130	I-29 SBL	87.45	County Road 1 mi North Interchange # 86	Underpass	16' 3"	No
	50-180-140	I-29 SBL	86.40	Renner Exit (County Road #6364) Interchange # 86	Interchange	16' 6"	Yes
		I-29 SBL	85.48	1.3 mi North of I-29 / I-90 Interchange	Sign Bridge	18' 9"	No
		I-29 SBL	84.46	0.3 mi North of I-90 Interchange	Sign Bridge	17' 6"	No
		I-29 SBL	84.17	North side of I29 / I-90 Interchange	Sign Bridge	17' 10"	No
50-180-163	50-180-162	I-29 SBL	84.10	I-90 Exit Interchange # 84	Interchange	16' 6"	No
		I-29 SBL	83.39	North of West 60th street over I-29S	Sign Bridge	18' 9"	No
	50-180-170	I-29 SBL	83.38	SD 38 / 60th Street Interchange # 83	Interchange	17' 1"	Yes
		I-29 SBL	82.91	.5 mi South of I-29 / W 60th Street Interchange	Cantilever Sign Bridge	17' 9"	Yes
		I-29 SBL	82.67	.25 mi North of I-29 / Benson Road Interchange	Sign Bridge	17' 10"	No
		I-29 SBL	82.09	South of Exit 82	Sign Bridge	18' 1"	No
		I-29 SBL	81.83	0.6 mi North Exit # 81	Sign Bridge	18' 9"	No
	50-178-191	I-29 SBL	81.83	2.0 mi S of SD 38E Interchange	Underpass	18' 8"	No

Secondary Structure	Structure Controlling Height	Hwy Number	MRM	Location	Structure Type	Maximum Permit Clearance	By-pass ?
	50-177-196	I-29 SBL	80.82	Pedestrian Bridge mi S of SD 38E Interchange	Ped Bridge	18' 8"	No
		I-29 SBL	80.79	.5 mi North of I-29 / Madison Street Interchange	Sign Bridge	19' 3"	No
		I-29 SBL	79.85	.6 mi North of I-29 / 12th Street Interchange	Sign Bridge	18' 10"	No
		I-29 SBL	79.76	.5 mi North of I-29 / 12th Street Interchange	Sign Bridge	18' 10"	No
		I-29 SBL	78.67	.55 mi North of I-29 / 26th Street Interchange	Cantilever Sign Bridge	19' 10"	Yes
		I-29 SBL	78.31	.2 mi North of I-29 / 26th Street Interchange	Cantilever Sign Bridge	19' 8"	Yes
	50-175-222	I-29 SBL	78.12	26th Street Exit Interchange # 78	Interchange	16' 8"	Yes
	50-175-230	I-29 SBL	77.26	41st Street Exit Interchange # 77	Interchange	18' 0"	Yes
		I-29 SBL	77.74	0.48 mi N of 41st St Interchange	Sign Bridge	17' 9"	No
		I-29 SBL	77.48	.22 mi North of I-29 / 41st Street Interchange	Sign Bridge	18' 0"	No
	50-173-235	I-29 SBL	76.72	49th Street 0.5 mi South Interchange # 77	Underpass	16' 6"	No
	50-172-240	I-29 SBL	76.19	57th Street 1.0 mi South Interchange #77	Underpass	17' 3"	No
		I-29 SBL	76.20	0.7 mi North I-229 Interchange	Sign Bridge	18' 1"	No
		I-29 SBL	75.85	0.4 miles North of I-29 / I-229 Interchange	Sign Bridge	18' 5"	No
		I-29 SBL	75.35	0.1 Miles North of I-29 / I-229 Interchange	Sign Bridge	18' 0"	No
		I-29 SBL	74.49	1.1 Miles North of Tea Interchange	Sign Bridge	18' 4"	No
		I-29 SBL	73.96	0.6 Miles North of Tea Interchange	Cantilever Sign Bridge	18' 6"	No
		I-29 SBL	73.59	0.2 Miles North of Tea Interchange	Cantilever Sign Bridge	18' 1"	No
	42-065-050	I-29 SBL	71.36	S. Tea Exit (County Road #6378) Interchange # 71	Interchange	16' 2"	Yes
	42-065-080	I-29 SBL	68.35	County Road # 6380 Interchange # 68	Interchange	16' 4"	Yes
	42-065-100	I-29 SBL	66.34	County Road 2 mi North Interchange # 64	Underpass	15' 11"	No

Secondary Structure	Structure Controlling Height	Hwy Number	MRM	Location	Structure Type	Maximum Permit Clearance	By-pass ?
	42-065-120	I-29 SBL	64.34	Worthing Exit (SD 44) Interchange # 64	Interchange	16' 0"	Yes
	42-065-130	I-29 SBL	63.34	County Road 1 mi North Interchange # 62	Underpass	15' 11"	No
	42-065-140	I-29 SBL	62.34	Canton Exit (US 18E) Interchange # 62	Interchange	17' 2"	Yes
	42-065-170	I-29 SBL	59.34	Davis Exit (US 18W) Interchange # 59	Interchange	15' 8"	Yes
	42-065-200	I-29 SBL	56.33	County Road # 6382 Interchange # 56	Interchange	15' 11"	Yes
	42-065-230	I-29 SBL	53.32	County Road # 6102 Interchange # 53	Interchange	16' 0"	Yes
	42-065-260	I-29 SBL	50.31	County Road # 6116 Interchange # 50	Interchange	15' 9"	Yes
	64-006-000	I-29 SBL	47.31	Beresford Exit (SD 46) Interchange # 47	Interchange	16' 9"	Yes
	64-006-010	I-29 SBL	46.31	County Road 1 mi South Interchange # 47	Underpass	16' 3"	No
	64-006-030	I-29 SBL	44.30	County Road 3 mi South Interchange # 47	Underpass	16' 5"	No
	64-006-090	I-29 SBL	38.32	Hub City Exit (County Road #6370) Interchange # 38	Interchange	16' 5"	Yes
	64-006-100	I-29 SBL	37.32	County Road 1 mi South Interchange # 38	Underpass	16' 6"	No
	64-006-120	I-29 SBL	35.31	County Road 4 mi North Interchange # 31	Underpass	16' 5"	No
	64-006-160	I-29 SBL	31.28	Spink Exit (SD 48) Interchange # 31	Interchange	16' 6"	Yes
	64-008-205	I-29 SBL	26.71	Junction City Exit (SD 50) Interchange # 26	Interchange	16' 6"	Yes
	64-020-220	I-29 SBL	24.72	County Road 2 mi South Interchange # 26	Underpass	17' 3"	No
	64-050-250	I-29 SBL	20.49	County Road 2 mi North Interchange # 18	Underpass	17' 8"	No
	64-070-287	I-29 SBL	15.79	S. Elk Point Exit (I-29 Loop) Interchange # 15	Interchange	16' 6"	No
	64-080-296	I-29 SBL	14.53	County Road 1.3 mi SE Interchange # 15	Underpass	16' 6"	No
	64-100-315	I-29 SBL	11.67	County Road # 6285 2 mi NW Interchange # 9	Underpass	16' 6"	No
	64-115-330	I-29 SBL	9.51	Jefferson Exit (old SD 105) Interchange # 9	Interchange	16' 6"	Yes

Secondary Structure	Structure Controlling Height	Hwy Number	MRM	Location	Structure Type	Maximum Permit Clearance	By-pass ?
	64-120-336	I-29 SBL	8.76	County Road 0.5 mi SE Interchange # 9	Underpass	16' 5"	No
	64-140-355	I-29 SBL	5.88	Horse Track Road 1.5 mi North Interchange # 4	Underpass	16' 7"	No
	64-149-367	I-29 SBL	4.35	McCook Lake Exit Interchange # 4	Interchange	16' 1"	Yes
	64-158-399	I-29 SBL	0.98	Dakota Dunes Exit Interchange # 1	Interchange	16' 2"	Yes
64-055-269	64-056-269	I-29 Loop	9.01	Elk Point Interchange # 18 I-29 MRM 18.31	Interchange	16' 9"	No
	41-095-059	I-90 EBL	10.30	US 85 N Exit Interchange # 10	Interchange	16' 2"	Yes
	41-101-077	I-90 EBL	12.32	Jackson Street Exit Interchange # 12	Interchange	16' 3"	Yes
	41-116-088	I-90 EBL	14.43	US 14 A Exit Interchange # 14	Interchange	17' 4"	Yes
41-155-087	41-154-087	I-90 EBL	18.17	US 85 S Exit Interchange # 17	Interchange	16' 5"	Yes
	41-185-086	I-90 EBL	21.56	County Road 3.5 mi East Interchange # 17	Underpass	20' 0"	No
	41-207-092	I-90 EBL	23.74	Whitewood Exit (SD 34) Interchange # 23	Interchange	16' 11"	Yes
	41-226-107	I-90 EBL	26.14	County Road 2.5 mi East Interchange # 23	Underpass	16' 11"	No
	47-061-480	I-90 EBL	37.01	County Road Interchange # 37	Interchange	17' 2"	Yes
	47-069-510	I-90 EBL	40.20	Tilford Exit Interchange # 40	Interchange	17' 3"	Yes
	47-098-563	I-90 EBL	46.14	S Piedmont Exit (County Road #6446) Interchange # 46	Interchange	16' 2"	Yes
	47-111-580	I-90 EBL	48.43	County Road Interchange # 48	Interchange	15' 9"	Yes
	47-135-609	I-90 EBL	52.31	1.0 mi NW Pennington Co Line	Underpass	19' 1"	No
	52-390-278	I-90 EBL	55.66	Deadwood Ave Exit (SD 445) Interchange # 55	Interchange	17' 11"	Yes
		I-90 EBL	56.70	1 mi East Deadwood Ave	Sign Bridge	18' 2"	No
		I-90 EBL	57.60	0.1 mi West I-190 Interchange	Sign Bridge	17' 0"	No
	52-410-285	I-90 EBL	57.77	I-190 Exit Interchange # 57	Interchange	16' 8"	No

Secondary Structure	Structure Controlling Height	Hwy Number	MRM	Location	Structure Type	Maximum Permit Clearance	By-pass ?
		I-90 EBL	58.08	0.3 mi East Ext 58	Cantilever Sign Bridge	18' 11"	No
		I-90 EBL	58.58	0.3 mi East Exit 57	Cantilever Sign Bridge	18' 8"	No
		I-90 EBL	58.93	0.3 mi West Exit 59	Cantilever Sign Bridge	17' 0"	No
	52-424-285	I-90 EBL	59.19	LaCrosse Street Exit/I-90 Exit Interchange # 59	Interchange	16' 8"	Yes
	52-425-285	I-90 EBL	59.23	LaCrosse Street Exit/I-90 Exit Interchange # 59	Interchange	19' 5"	Yes
	52-450-287	I-90 EBL	61.84	Elk Vale Road Exit Interchange # 61 (US 16B)	Interchange	18' 1"	Yes
	52-467-276	I-90 EBL	63.86	SD 230 W 2 mi East Interchange # 61	Underpass	17' 3"	No
	52-470-276	I-90 EBL	64.16	2.3 mi East of the Elk Vale Interchange	Underpass	16' 5"	No
		I-90 EBL	66.78	Ellsworth AFB 0.8 mi West Interchange # 66	Sign Bridge	18' 8"	No
	52-500-275	I-90 EBL	67.15	Ellsworth AFB Exit Interchange #67	Interchange	16' 8"	No
	52-540-275	I-90 EBL	71.13	County Road 5 mi East Interchange # 66	Underpass	15' 10"	No
	52-610-285	I-90 EBL	78.29	New Underwood Exit (SD 423) Interchange # 78	Interchange	17' 5"	Yes
	52-640-285	I-90 EBL	81.27	County Road 3 mi East Interchange # 78	Underpass	17' 3"	No
	52-670-285	I-90 EBL	84.24	County Road Interchange # 84	Interchange	17' 1"	Yes
	52-710-283	I-90 EBL	88.23	County Road Interchange # 88	Interchange	18' 0"	No
	52-830-310	I-90 EBL	101.23	County Road Interchange # 101	Interchange	17' 11"	No
	52-880-346	I-90 EBL	107.85	County Road Interchange # 107	Interchange	16' 4"	Yes
	52-900-360	I-90 EBL	109.82	W. Wall Exit (SD 240) Interchange # 109	Interchange	16' 4"	Yes
52-926-366	52-925-365	I-90 EBL	112.61	US 14 E Exit Interchange # 112	Interchange	17' 0"	No
	36-120-107	I-90 EBL	131.27	Cactus Flat Exit (SD 240) Interchange # 131	Interchange	16' 6"	Yes
	36-309-106	I-90 EBL	150.20	Kadoka Exit (US 73) Interchange # 150	Interchange	16' 1"	Yes

Secondary Structure	Structure Controlling Height	Hwy Number	MRM	Location	Structure Type	Maximum Permit Clearance	By-pass ?
	38-030-185	I-90 EBL	177.48	County Road # 6511 Interchange # 177	Interchange	16' 4"	Yes
	38-166-196	I-90 EBL	191.15	W. Murdo Exit (SD 248) Interchange # 191	Interchange	15' 4"	Yes
	38-180-198	I-90 EBL	192.65	E. Murdo Exit (US 83S) Interchange # 192	Interchange	16' 6"	Yes
	43-026-195	I-90 EBL	212.81	Vivian Exit (US 83N) Interchange # 212	Interchange	17' 1"	Yes
		I-90 EBL	263.30	East End Missouri Rv. Br.	Sign Bridge	18' 10"	No
	08-069-103	I-90 EBL	264.39	I-90 Rest Area 0.8 mi East Interchange # 263	Underpass	15' 11"	Yes
	08-080-112	I-90 EBL	265.86	E. Chamberlain Exit (SD 50) Interchange # 265	Interchange	15' 11"	Yes
	08-120-125	I-90 EBL	270.14	County Road 4.3 mi East Interchange # 265	Underpass	15' 10"	No
	08-145-124	I-90 EBL	272.64	Pukwana Exit (SD 50) Interchange # 272	Interchange	16' 6"	Yes
	08-290-135	I-90 EBL	287.21	County Road 3.2 mi East Interchange # 284	Underpass	16' 0"	No
	08-310-135	I-90 EBL	289.23	SD 45S Exit Interchange # 289	Interchange	15' 9"	Yes
	02-000-135	I-90 EBL	292.22	County Road 3 mi East Interchange # 289	Underpass	15' 10"	No
	02-018-140	I-90 EBL	294.14	County Road # 6548 5 mi East Interchange # 289	Underpass	17' 1"	No
	02-040-149	I-90 EBL	296.68	County Road # 6169 White Lake Exit Interchange # 296	Interchange	15' 11"	Yes
	02-070-155	I-90 EBL	299.74	County Road 3 mi East Interchange # 296	Underpass	16' 7"	No
	02-100-155	I-90 EBL	302.76	County Road # 6119 6 mi East Interchange # 296	Underpass	16' 7"	No
	02-140-155	I-90 EBL	306.15	County Road 9.5 mi East Interchange # 296	Underpass	16' 6"	No
	02-15C-158	I-90 EBL	308.26	Plankinton Exit (SD 258) Interchange # 308	Interchange	16' 10"	Yes
	02-180-165	I-90 EBL	310.49	US 281 Exit Interchange # 310	Interchange	16' 7"	Yes
	02-220-165	I-90 EBL	314.43	County Road 4 mi East Interchange # 310	Underpass	16' 5"	No
	18-010-105	I-90 EBL	317.47	County Road 7 mi East Interchange # 310	Underpass	16' 4"	No

Secondary Structure	Structure Controlling Height	Hwy Number	MRM	Location	Structure Type	Maximum Permit Clearance	By-pass ?
	18-030-105	I-90 EBL	319.43	Mt. Vernon Exit Interchange # 319	Interchange	16' 5"	Yes
	18-050-105	I-90 EBL	321.43	County Road 2 mi East Interchange # 319	Underpass	16' 8"	No
	18-070-105	I-90 EBL	323.42	County Road 4 mi East Interchange # 319	Underpass	16' 6"	No
	18-090-105	I-90 EBL	325.42	Betts Exit (County Road #6221) Interchange # 325	Interchange	16' 10"	Yes
	18-120-105	I-90 EBL	328.41	County Road # 6351 3 mi East Interchange # 325	Underpass	16' 6"	No
	18-140-107	I-90 EBL	330.42	Mitchell Exit (I-90 Loop & SD37) Interchange # 330	Interchange	17' 2"	Yes
	31-040-105	I-90 EBL	338.42	County Road # 6229 3 mi East Interchange # 335	Underpass	16' 9"	No
	31-090-126	I-90 EBL	344.02	Alexandria Exit (SD 262) Interchange # 344	Interchange	16' 9"	Yes
	31-120-126	I-90 EBL	347.04	County Road 3 mi East Interchange # 344	Underpass	16' 3"	No
	31-150-125	I-90 EBL	350.06	SD 25 Exit Interchange # 350	Interchange	16' 3"	Yes
	31-160-125	I-90 EBL	351.06	County Road 1 mi East Interchange # 350	Underpass	16' 10"	No
	44-010-126	I-90 EBL	353.98	Spencer Exit (County Road #6341) Interchange # 353	Interchange	17' 0"	Yes
	44-050-127	I-90 EBL	357.99	Bridgewater Exit County Road #6211 Interchange # 357	Interchange	17' 1"	Yes
	44-080-125	I-90 EBL	361.05	County Road 3 mi East Interchange # 357	Underpass	17' 3"	No
	44-110-125	I-90 EBL	364.02	Salem Exit (US 81) Interchange # 364	Interchange	16' 5"	Yes
	44-150-126	I-90 EBL	368.05	County Road # 6355 Interchange # 368	Interchange	16' 6"	Yes
	44-170-126	I-90 EBL	370.04	County Road 2 mi East Interchange # 368	Underpass	16' 6"	No
	44-210-126	I-90 EBL	374.02	Montrose Exit Interchange # 374	Interchange	16' 6"	Yes
	50-030-149	I-90 EBL	380.93	County Road 1.3 mi SE Interchange # 379	Underpass	16' 1"	No
	50-050-164	I-90 EBL	383.46	County Road 3.5 mi SE Interchange # 379	Underpass	16' 3"	No
	50-070-165	I-90 EBL	385.45	County Road 2 mi West Interchange # 387	Underpass	15' 10"	No

Secondary Structure	Structure Controlling Height	Hwy Number	MRM	Location	Structure Type	Maximum Permit Clearance	By-pass ?
	50-090-165	I-90 EBL	387.46	Hartford Exit (County Road #6353) Interchange # 387	Interchange	16' 1"	Yes
	50-160-166	I-90 EBL	394.45	County Road # 6361 4.2 mi East Interchange # 390	Underpass	16' 3"	No
	50-170-164	I-90 EBL	395.46	County Road 5.2 mi East Interchange # 390	Underpass	16' 9"	No
		I-90 EBL	395.90	.65 mi West of I-90 / I-29 Interchange	Cantilever Sign Bridge	18' 2"	Yes
		I-90 EBL	396.21	0.35 mi West I-29 Interchange	Sign Bridge	19' 4"	No
		I-90 EBL	396.56	.01 mi East of I-90 / I-29 Interchange	Cantilever Sign Bridge	18' 8"	Yes
	50-185-163	I-90 EBL	396.98	County Road 0.5 mi East Interchange # 396	Underpass	16' 8"	No
		I-90EBL	400.04	0.56 miles West of I90/I229 Interchange	Cantilever Sign Bridge	19' 10"	Yes
		I-90 EBL	400.29	0.31 miles West of I90/I229 Interchange	Sign Bridge	17' 10"	No
	50-240-165	I-90 EBL	402.55	County Road # 6195 2 mi East Interchange # 400	Interchange	18' 0"	Yes
	50-280-165	I-90 EBL	406.55	Brandon Exit (SD 11) Interchange # 406	Interchange	17' 0"	Yes
	50-300-166	I-90 EBL	408.56	County Road 2 mi East Interchange # 406	Underpass	16' 9"	No
	50-320-166	I-90 EBL	410.57	County Road # 6347 Interchange # 410	Interchange	16' 4"	Yes
	50-320-166	I-90 WBL	410.57	County Road # 6347 Interchange # 410	Interchange	18' 3"	Yes
	50-300-166	I-90 WBL	408.56	County Road 2 mi East Interchange # 406	Underpass	18' 8"	No
	50-280-165	I-90 WBL	406.55	Brandon Exit (SD 11) Interchange # 406	Interchange	17' 3"	Yes
	50-240-165	I-90 WBL	402.55	County Road Exit 2 mi East Interchange # 400	Interchange	18' 8"	Yes
		I-90 WBL	401.49	0.9 mi East I-229 Interchange	Sign Bridge	17' 2"	No
		I-90 WBL	400.53	0.07 miles West I-90/I-229 Interchange	Sign Bridge	18' 2"	No
		I-90WBL	400.16	0.44 miles West of I-90/I-229 Interchange	Cantilever Sign Bridge	18' 7"	Yes
		I-90WBL	399.80	0.80 miles West of I-90/I-229 Interchange	Sign Bridge	18' 3"	No

Secondary Structure	Structure Controlling Height	Hwy Number	MRM	Location	Structure Type	Maximum Permit Clearance	By-pass ?
		I-90 WBL	397.79	1.25 mi East of I-90 / I-29 Interchange	Sign Bridge	18' 10"	No
	50-185-163	I-90 WBL	396.98	County Road 0.5 mi East Interchange # 396	Underpass	16' 0"	No
		I-90 WBL	396.79	0.25 mi East I-29 Interchange	Sign Bridge	18' 1"	No
		I-90 WBL	396.48	.05 mi West of I-90 / I-29 Interchange	Sign Bridge	18' 9"	No
		I-90 WBL	395.97	.51 mi East of I-90 / Marion Road Interchange	Cantilever Sign Bridge	18' 8"	Yes
	50-170-164	I-90 WBL	395.46	County Road 5.2 mi East Interchange # 390	Underpass	16' 7"	No
	50-160-166	I-90 WBL	394.45	County Road # 6361 4.2 mi East Interchange # 390	Underpass	17' 6"	No
	50-090-165	I-90 WBL	387.46	Hartford Exit (County Road #6353) Interchange # 387	Interchange	16' 0"	Yes
	50-070-165	I-90 WBL	385.45	County Road 2 mi West Interchange # 387	Underpass	16' 10"	No
	50-050-164	I-90 WBL	383.46	County Road mi SE Interchange # 379	3.5 Underpass	17' 0"	No
	50-030-149	I-90 WBL	380.93	County Road 1.3 mi SE Interchange # 379	Underpass	17' 3"	No
	44-210-126	I-90 WBL	374.02	Montrose Exit County Road #6149 Interchange # 374	Interchange	16' 7"	Yes
	44-170-126	I-90 WBL	370.04	County Road 2 mi East Interchange # 368	Underpass	16' 8"	No
	44-150-126	I-90 WBL	368.05	County Road # 6355 Interchange # 368	Interchange	16' 6"	Yes
	44-110-125	I-90 WBL	364.02	Salem Exit (US 81) Interchange # 364	Interchange	16' 4"	Yes
	44-080-125	I-90 WBL	361.05	County Road 3 mi East Interchange # 357	Underpass	17' 1"	No
	44-050-127	I-90 WBL	357.99	Bridgewater Exit County Road #6211 Interchange # 357	Interchange	17' 2"	Yes
	44-010-126	I-90 WBL	353.98	Spencer Exit (County Road #6341) Interchange # 353	Interchange	17' 1"	Yes
	31-160-125	I-90 WBL	351.06	County Road 1 mi East Interchange # 350	Underpass	16' 11"	No
	31-150-125	I-90 WBL	350.06	SD 25 Exit Interchange # 350	Interchange	17' 0"	Yes
	31-120-126	I-90 WBL	347.04	County Road 3 mi East Interchange # 344	Underpass	16' 9"	No

Secondary Structure	Structure Controlling Height	Hwy Number	MRM	Location	Structure Type	Maximum Permit Clearance	By-pass ?
	31-090-126	I-90 WBL	344.02	Alexandria Exit (SD 262) Interchange # 344	Interchange	16' 10"	Yes
	31-040-105	I-90 WBL	338.42	County Road # 6229 3 mi East Interchange # 335	Underpass	16' 11"	No
	18-140-107	I-90 WBL	330.42	Mitchell Exit (I-90 Loop & SD37) Interchange # 330	Interchange	17' 2"	Yes
	18-120-105	I-90 WBL	328.41	County Road # 6351 3 mi East Interchange # 325	Underpass	16' 4"	No
	18-090-105	I-90 WBL	325.42	Betts Exit (County Road #6221) Interchange # 325	Interchange	16' 6"	Yes
	18-070-105	I-90 WBL	323.42	County Road 4 mi East Interchange # 319	Underpass	16' 6"	No
	18-050-105	I-90 WBL	321.43	County Road 2 mi East Interchange # 319	Underpass	16' 5"	No
	18-030-105	I-90 WBL	319.43	Mt. Vernon Exit Interchange # 319	Interchange	16' 3"	Yes
	18-010-105	I-90 WBL	317.47	County Road 7 mi East Interchange # 310	Underpass	16' 4"	No
	02-220-165	I-90 WBL	314.43	County Road 4 mi East Interchange # 310	Underpass	16' 3"	No
	02-180-165	I-90 WBL	310.49	US 281 Exit Interchange # 310	Interchange	16' 5"	Yes
	02-15C-158	I-90 WBL	308.26	Plankinton Exit (SD 258) Interchange # 308	Interchange	16' 3"	Yes
	02-140-155	I-90 WBL	306.15	County Road 2 mi West Interchange # 308	Underpass	16' 3"	No
	02-100-155	I-90 WBL	302.76	County Road 6 mi East Interchange # 296	Underpass	16' 4"	No
	02-070-155	I-90 WBL	299.74	County Road 3 mi East Interchange # 296	Underpass	16' 4"	No
	02-040-149	I-90 WBL	296.68	White Lake Exit County Road #6169 Interchange # 296	Interchange	15' 11"	Yes
	02-018-140	I-90 WBL	294.14	County Road 5 mi East Interchange # 289	Underpass	16' 2"	No
	02-000-135	I-90 WBL	292.22	County Road 3 mi East Interchange # 289	Underpass	15' 10"	No
	08-310-135	I-90 WBL	289.23	SD 45 Exit Interchange # 289	Interchange	15' 8"	Yes
	08-290-135	I-90 WBL	287.21	County Road 3.2 mi East Interchange # 284	Underpass	15' 10"	No
	08-145-124	I-90 WBL	272.64	Pukwana Exit (SD 50) Interchange # 272	Interchange	16' 1"	Yes

Secondary Structure	Structure Controlling Height	Hwy Number	MRM	Location	Structure Type	Maximum Permit Clearance	By-pass ?
	08-120-125	I-90 WBL	270.14	County Road 4.3 mi East Interchange # 265	Underpass	15' 11"	No
	08-080-112	I-90 WBL	265.86	E. Chamberlain Exit (SD 50) Interchange # 265	Interchange	15' 9"	Yes
	08-069-103	I-90 WBL	264.39	I-90 Rest Area 0.8 mi East Interchange # 263	Underpass	16' 1"	No
		I-90 WBL	263.30	East End Missouri Rv. Br.	Sign Bridge	19' 6"	No
	43-026-195	I-90 WBL	212.81	Vivian Exit (US 83N) Interchange # 212	Interchange	15' 9"	Yes
	38-180-198	I-90 WBL	192.65	E. Murdo Exit (US 83S) Interchange # 192	Interchange	17' 1"	Yes
	38-166-196	I-90 WBL	191.15	W. Murdo Exit (SD 248) Interchange # 191	Interchange	15' 7"	Yes
	38-030-185	I-90 WBL	177.48	County Road # 6511 Interchange # 177	Interchange	16' 5"	Yes
	36-309-106	I-90 WBL	150.20	Kadoka Exit (US 73) Interchange # 150	Interchange	15' 11"	Yes
	36-120-107	I-90 WBL	131.27	Cactus Flat Exit (SD 240) Interchange # 131	Interchange	15' 8"	Yes
52-926-366	52-925-365	I-90 WBL	112.61	US 14 E Exit Interchange # 112	Interchange	15' 9"	No
	52-900-360	I-90 WBL	109.82	W. Wall Exit (SD 240) Interchange # 109	Interchange	16' 2"	Yes
	52-880-346	I-90 WBL	107.85	County Road # 6188 Interchange # 107	Interchange	16' 11"	Yes
	52-830-310	I-90 WBL	101.23	County Road Interchange # 101	Interchange	16' 2"	No
	52-710-283	I-90 WBL	88.23	County Road Interchange # 88	Interchange	19' 3"	No
	52-670-285	I-90 WBL	84.24	County Road Interchange # 84	Interchange	18' 2"	Yes
	52-640-285	I-90 WBL	81.27	County Road 3 mi East Interchange # 78	Underpass	16' 8"	No
	52-610-285	I-90 WBL	78.29	New Underwood Exit Interchange # 78 (SD 423)	Interchange	19' 8"	Yes
	52-540-275	I-90 WBL	71.13	County Road 5 mi East Interchange # 66	Underpass	18' 7"	No
	52-500-275	I-90 WBL	67.15	Ellsworth AFB Exit Interchange #67	Interchange	17' 0"	No
	52-470-276	I-90 WBL	64.16	2.3 mi East of the Elk Vale Interchange	Underpass	17' 9"	No

Secondary Structure	Structure Controlling Height	Hwy Number	MRM	Location	Structure Type	Maximum Permit Clearance	By-pass ?
	52-467-276	I-90 WBL	63.86	SD 230 W 2 mi East Interchange # 61	Underpass	16' 7"	No
	52-450-287	I-90 WBL	61.84	Elk Vale Road Exit Interchange # 61 (US 16B)	Interchange	16' 7"	Yes
	52-424-285	I-90 WBL	59.19	LaCrosse Street Exit/I-90 Exit Interchange # 59	Interchange	16' 4"	Yes
	52-425-285	I-90 WBL	59.23	LaCrosse Street Exit/I-90 Exit Interchange # 59	Interchange	18' 8"	Yes
		I-90 WBL	58.87	0.3 mi West Exit 59	Cantilever Sign Bridge	18' 7"	No
		I-90 WBL	58.59	0.3 mi East Exit 57	Cantilever Sign Bridge	18' 9"	No
		I-90 WBL	58.10	0.2 W Haines Ave Interchange	Sign Bridge	17' 6"	No
	52-410-285	I-90 WBL	57.77	I-190 Exit Interchange # 57	Interchange	17' 3"	No
	52-390-278	I-90 WBL	55.66	Deadwood Ave Exit Interchange # 55 (SD 445)	Interchange	17' 11"	Yes
	47-135-609	I-90 WBL	52.31	1.0 mi NW Pennington Co Line	Underpass	17' 6"	No
	47-111-580	I-90 WBL	48.43	County Road Interchange # 48	Interchange	15' 9"	Yes
	47-098-563	I-90 WBL	46.14	S. Piedmont Exit County Road # 6446 Interchange # 46	Interchange	15' 9"	Yes
	47-069-510	I-90 WBL	40.20	Tilford Exit Interchange # 40	Interchange	16' 9"	Yes
	47-061-480	I-90 WBL	37.01	County Road Interchange # 37	Interchange	18' 3"	Yes
	41-226-107	I-90 WBL	26.14	County Road 2.5 mi East Interchange # 23	Underpass	18' 0"	No
	41-207-092	I-90 WBL	23.74	Whitewood Exit (SD 34) Interchange # 23	Interchange	17' 0"	Yes
	41-185-086	I-90 WBL	21.56	County Road 3.5 mi East Interchange # 17	Underpass	17' 4"	No
41-155-087	41-154-087	I-90 WBL	18.17	US 85 S Exit Interchange # 17	Interchange	18' 11"	Yes
	41-116-088	I-90 WBL	14.43	US 14 A Exit Interchange # 14	Interchange	17' 0"	Yes
	41-101-077	I-90 WBL	12.32	Jackson Street Exit Interchange # 12	Interchange	17' 8"	Yes
	41-095-059	I-90 WBL	10.30	US 85 N Exit Interchange # 10	Interchange	16' 6"	Yes

Secondary Structure	Structure Controlling Height	Hwy Number	MRM	Location	Structure Type	Maximum Permit Clearance	By-pass ?
43-485-273	43-485-272	I-90 Loop	260.46	Oacoma Exit I-90 Interchange # 260	Interchange	15' 10"	No
	08-068-084	I-90 Loop	263.86	Missouri River at Chamberlain	Overhead Truss	15' 4"	No
18-157-108	18-157-107	I-90 Loop NBL	332.18	Mitchell I-90 Interchange # 332	Underpass	16' 0"	No
18-157-108	18-157-107	I-90 Loop SBL	332.18	Mitchell I-90 Interchange # 332	Underpass	16' 0"	No
		I-190 N	0.12	0.1 mi North Jct SD 44	Sign Bridge	18' 7"	No
		I-190 N	0.21	0.2 mi North of Jct. SD 44	Cantilever Hwy Sign	18' 1"	No
	52-410-290	I-190 N	0.87	Anamosa Street 0.5 mi South I-90 Interchange	Underpass	17' 2"	No
	52-410-289	I-190 N	0.87	Temporary Pedestrian Bridge 0.5 mi South of Exit 57	Pedestrian Bridge	16' 3"	No
		I-190 N	1.07	1.1 mi North Jct SD 44	Sign Bridge	16' 10"	No
		I-190 N	1.26	1.3 mi North Jct SD 44	Sign Bridge	19' 1"	No
		I-190 S	0.12	0.1 mi North Jct SD 44	Sign Bridge	16' 7"	No
	52-410-289	I-190 S	0.87	Temporary Pedestrian Bridge 0.5 mi South of Exit 57	Pedestrian Bridge	16' 3"	No
	52-410-290	I-190 S	0.87	Anamosa Street 0.5 mi South I-90 Interchange	Underpass	17' 4"	No
	42-070-006	I-229 N	0.10	Solberg Avenue over I-229	Underpass	18' 2"	No
		I-229 N	0.61	0.27 miles East of I-29 / I-229 Interchange	Sign Bridge	18' 7"	No
42-067-006	42-066-006	I-229 N	0.82	I-229 Interchange I-29 Interchange # 75	Interchange	18' 5"	No
	42-079-004	I-229 N	0.93	Louise Ave Interchange Interchange # 1	Interchange	16' 5"	Yes
		I-229 N	1.01	North of Louise Ave. Bridge.	Sign Bridge	18' 10"	No
		I-229 N	1.89	.2 mi South of Western Ave. Interchange	Sign Bridge	18' 1"	No
	50-191-238	I-229 N	2.08	Western Ave Interchange Interchange # 2	Interchange	16' 2"	Yes

Secondary Structure	Structure Controlling Height	Hwy Number	MRM	Location	Structure Type	Maximum Permit Clearance	By-pass ?
		I-229 N	2.38	0.75 mi South Minnesota Ave (Overhangs exit lane)	Cantilever Hwy Sign	17' 7"	Yes
		I-229 N	2.82	Minnesota Ave Exit (Overhangs exit lane)	Cantilever Hwy Sign	17' 5"	Yes
		I-229 N	3.45	0.5 mi South Cliff Ave (Overhangs exit lane)	Cantilever Hwy Sign	17' 1"	Yes
		I-229 N	3.90	Cliff Ave Exit (Overhangs exit lane)	Cantilever Hwy Sign	17' 2"	Yes
		I-229 N	4.48	0.85 mi South 26th Street (Overhangs exit lane)	Cantilever Hwy Sign	17' 5"	Yes
		I-229 N	4.92	0.4 mi South of 26th Street Exit (Overhangs exit lane)	Cantilever Hwy Sign	17' 3"	Yes
	50-216-220	I-229 N	5.32	26th Street Interchange Interchange # 5	Interchange	16' 1"	No
	50-219-215	I-229 N	5.95	18th Street 0.6 mi North Interchange # 5	Underpass	16' 2"	No
	50-219-210	I-229 N	6.47	12th Street South Interchange # 6	Underpass	16' 5"	No
	50-219-208	I-229 N	6.67	SD 42 Interchange Interchange # 6	Interchange	17' 1"	Yes
	50-219-205	I-229 N	6.95	6th Street 0.3 mi North Interchange # 6	Underpass	16' 3"	No
		I-229 N	7.11	0.75 mi South Rice St (Overhangs exit lane)	Cantilever Hwy Sign	17' 4"	Yes
		I-229 N	7.80	Rice St Exit (Overhangs exit lane)	Cantilever Hwy Sign	17' 10"	Yes
		I-229 N	8.57	0.9 mi South I-229/Benson Road (Overhangs exit lane)	Cantilever Hwy Sign	17' 9"	Yes
		I-229 N	9.04	Benson Road Exit (Overhangs exit lane)	Cantilever Hwy Sign	17' 5"	Yes
	50-219-180	I-229 N	9.46	Benson Road Interchange # 9	Interchange	16' 8"	Yes
		I-229 N	10.41	0.4 mi South of I-229 Interchange	Sign Bridge	18' 1"	No
	50-221-170	I-229 N	10.47	County Road # 1186 0.3 mi South I-90	Underpass	19' 3"	No
		I-229 N	10.77	0.05 mi South of I-229 Interchange	Sign Bridge	18' 4"	No
50-221-167	50-221-166	I-229 N	10.81	I-90 E Interchange Interchange # 10	Interchange	17' 3"	No
	42-070-006	I-229 S	0.10	Solberg Avenue over I-229	Underpass	19' 4"	No

Secondary Structure	Structure Controlling Height	Hwy Number	MRM	Location	Structure Type	Maximum Permit Clearance	By-pass ?
42-067-006	42-066-006	I-229 S	0.82	I-229 Interchange I-29 Interchange # 75	Interchange	18' 6"	No
		I-229 S	0.86	0.35 miles East of I-29 / I-229 Interchange	Sign Bridge	18' 4"	No
		I-229 S	0.89	0.75 miles East of I-29 / I-229 Interchange	Sign Bridge	18' 7"	Yes
	42-079-004	I-229 S	0.93	Louise Avenue Interchange Interchange # 1	Interchange	16' 9"	Yes
		I-229 S	0.95	0.02 miles East of I-229/Louise Avenue Interchange	Sign Bridge	17' 11"	No
		I-229 S	1.31	East Louise Ave. Interchange	Sign Bridge	16' 8"	No
		I-229 S	1.78	0.85 mi East of Louise Ave. Interchange	Sign Bridge	17' 5"	No
	50-191-238	I-229 S	2.08	Western Ave Interchange Interchange # 2	Interchange	16' 3"	Yes
		I-229 S	2.25	Western Ave Exit (Overhangs exit lane)	Cantilever Hwy Sign	17' 11"	Yes
		I-229 S	2.69	0.5 mi North Western Ave (Overhangs exit lane)	Cantilever Hwy Sign	17' 8"	Yes
		I-229 S	3.18	Minnesota Ave Exit (Overhangs exit lane)	Cantilever Hwy Sign	17' 7"	Yes
		I-229 S	3.67	0.5 mi North Minnesota Ave (Overhangs exit lane)	Cantilever Hwy Sign	17' 6"	Yes
		I-229 S	4.52	Cliff Ave Exit (Overhangs exit lane)	Cantilever Hwy Sign	17' 10"	Yes
		I-229 S	4.97	0.55 mi South 26th Street Interchange (Overhangs exit lane)	Cantilever Hwy Sign	17' 5"	Yes
	50-216-220	I-229 S	5.32	26th Street Interchange Interchange # 5	Interchange	16' 8"	No
	50-219-215	I-229 S	5.95	18th Street 0.6 mi North Interchange # 5	Underpass	17' 1"	No
	50-219-210	I-229 S	6.47	12th Street South Interchange # 6	Underpass	16' 7"	No
	50-219-208	I-229 S	6.67	SD 42 Interchange Interchange # 6	Interchange	16' 7"	Yes
		I-229 S	6.95	0.9 mi South of Rice Street Interchange (Overhangs exit lane)	Cantilever Hwy Sign	17' 8"	Yes
	50-219-205	I-229 S	6.95	6th Street 0.6 mi North Interchange # 6	Underpass	17' 0"	No

Secondary Structure	Structure Controlling Height	Hwy Number	MRM	Location	Structure Type	Maximum Permit Clearance	By-pass ?
		I-229 S	7.49	0.35 mi South of Rice Street Interchange(Overhangs exit lane)	Cantilever Hwy Sign	17' 8"	Yes
		I-229 S	8.08	Rice Street Exit (Overhangs exit lane)	Cantilever Hwy Sign	17' 7"	Yes
		I-229 S	8.84	0.6 mi South of Benson Road Interchange (Overhangs exit lane)	Cantilever Hwy Sign	17' 8"	Yes
	50-219-180	I-229 S	9.46	Benson Road Interchange # 9	Interchange	16' 7"	Yes
	50-221-170	I-229 S	10.47	County Road # 1186 0.3 mi South Interchange # 10	Underpass	18' 10"	No
50-221-167	50-221-166	I-229 S	10.81	I-90 Interchange Interchange # 10	Interchange	17' 2"	No

US Hwys

	65-000-020	US 12	187.15	Missouri River at Mobridge Actual Width of Bridge is 26'0"	Overhead Truss	17' 0"	No
		US 12 W	289.97	Aberdeen - 5th St	Cantilever RR Signal	17' 5"	

Hwy 12-Aberdeen

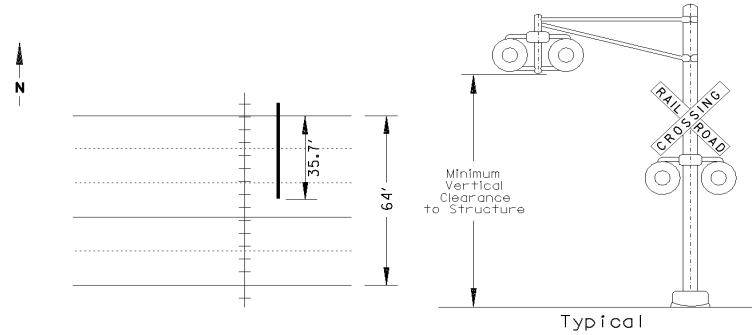

		US 14	130.60	Between Philip and Cottonwood	Cantilever RR Signal	17' 7"	
--	--	-------	--------	-------------------------------	----------------------	--------	--

Secondary Structure	Structure Controlling Height	Hwy Number	MRM	Location	Structure Type	Maximum Permit Clearance	By-pass ?
---------------------	------------------------------	------------	-----	----------	----------------	--------------------------	-----------

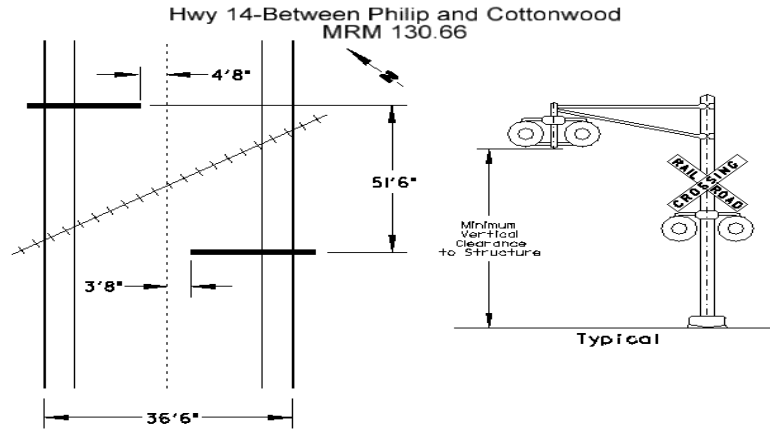

		US 14	227.64	In Ft. Pierre W. of JCT 83	Cantilever RR Signal	17' 3"	
--	--	-------	--------	----------------------------	----------------------	--------	--

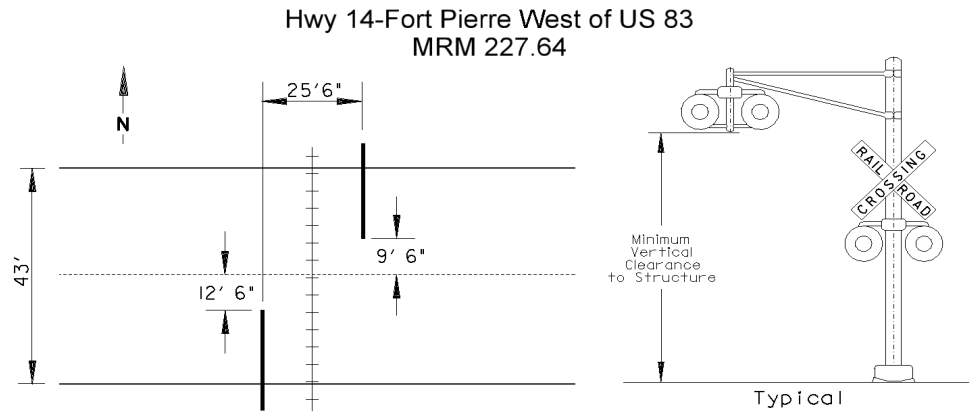

		US 14	229.10	Downtown Pierre	Sign Bridge	17' 1"	No
	33-108-121	US 14	229.20	Downtown Pierre	Railroad Underpass	11' 1"	Yes
		US 14 E Bypass	231.67	Garfield Ave East End of Pierre	Cantilever Hwy Sign	18' 4"	
		US 14 W Bypass	231.67	Garfield Ave East End of Pierre	Cantilever Hwy Sign	17' 8"	
	03-254-180	US 14 E	347.06	1.4 mi East of SD 37 (Riverside Drive NE)	Underpass	15' 10"	Yes
	03-254-180	US 14 W	347.06	1.4 mi East of SD 37 (Riverside Drive NE)	Underpass	15' 10"	Yes
	06-154-150	US 14 E Bypass	418.23	Under US 14 W 2.5 mi West I-29 - Brookings	Underpass	15' 4"	No
	06-154-150	US 14 W Bypass	418.23	Under US 14 W 2.5 mi West I-29 - Brookings	Underpass	16' 4"	No

Secondary Structure	Structure Controlling Height	Hwy Number	MRM	Location	Structure Type	Maximum Permit Clearance	By-pass ?
		US 14 A	52.82	In Sturgis -West of I-90	Cantilever RR Signal	17' 2"	

Hwy 14A - Sturgis

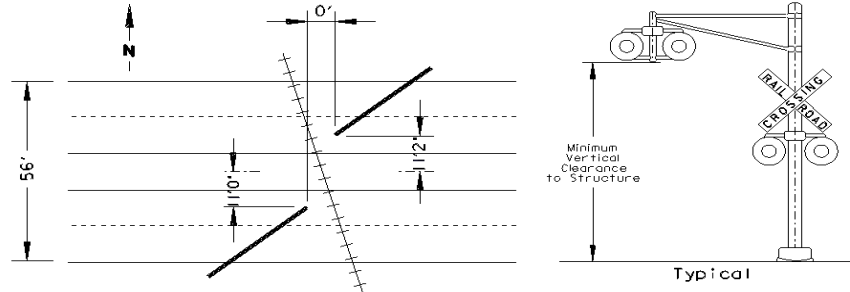

47-018-428	47-018-430	US 14 A	52.98	Sturgis Interchange I-90 MRM 30.28 (Exit 30)	Interchange	19' 4"	No
		US 14 B	229.96	In Pierre - Sioux Ave	Cantilever RR Signal	17' 4"	

Hwy 14B - Pierre

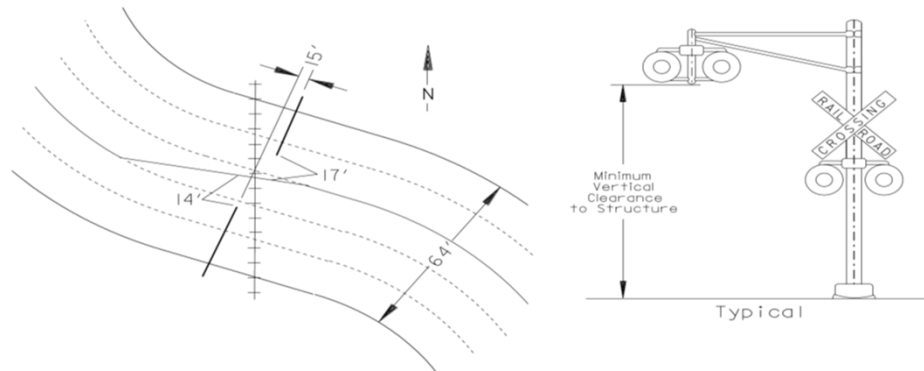

		US 14	330.47	Wolsey	Cantilever RR Signal	17' 2"	
--	--	-------	--------	--------	----------------------	--------	--

Hwy 14 - Wolsey

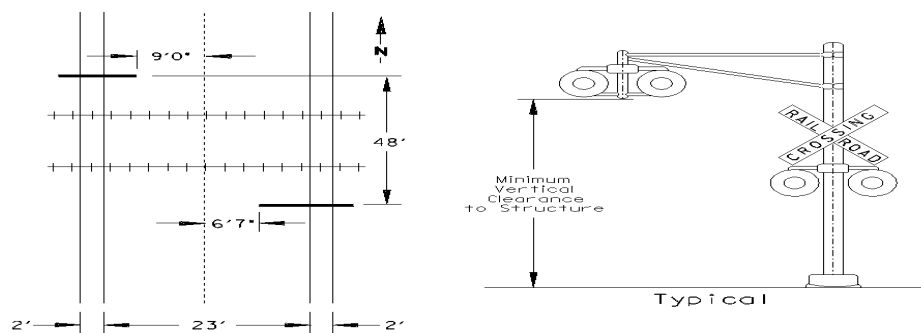

Secondary Structure	Structure Controlling Height	Hwy Number	MRM	Location	Structure Type	Maximum Permit Clearance	By-pass ?
		US 14 E	343.82	Huron - W of SD 37	Cantilever RR Signal	17' 7"	
		US 14 W	343.82	Huron - W of SD 37	Cantilever RR Signal	17' 11"	

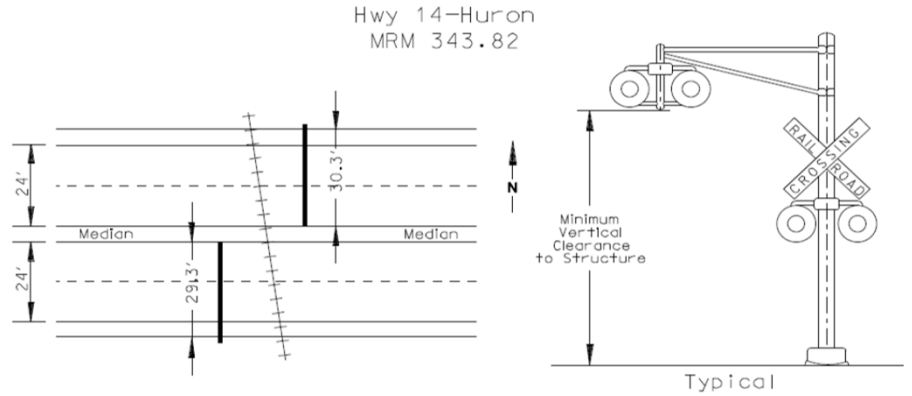

		US 14 E	345.07	Huron - W of SD 37	Cantilever RR Signal	17' 4"	
		US 14 W	345.07	Huron - W of SD 37	Cantilever RR Signal	16' 8"	

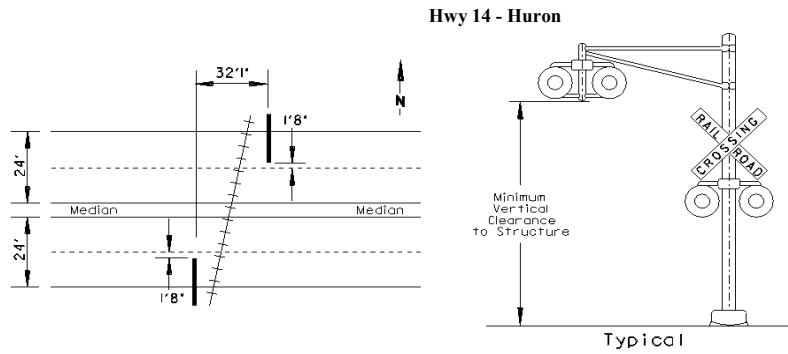

		US 14	364.34	E of Iroquois	Cantilever RR Signal	16' 7"	
--	--	-------	--------	---------------	----------------------	--------	--

Secondary Structure	Structure Controlling Height	Hwy Number	MRM	Location	Structure Type	Maximum Permit Clearance	By-pass ?
---------------------	------------------------------	------------	-----	----------	----------------	--------------------------	-----------

Hwy 14 - East of Iroquois

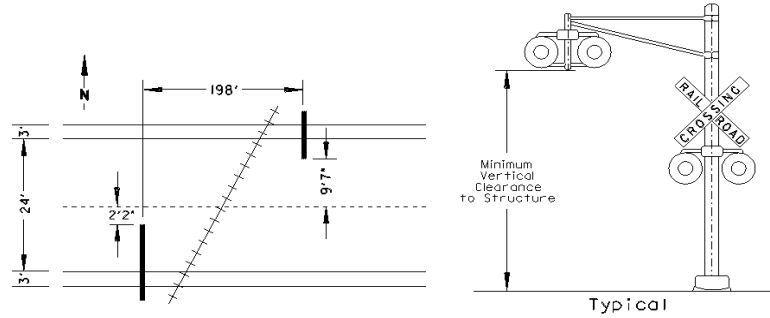

		US 14	411.86	W of Volga	Cantilever RR Signal	17' 5"	
--	--	-------	--------	------------	----------------------	--------	--

Hwy 14 - West of Volga

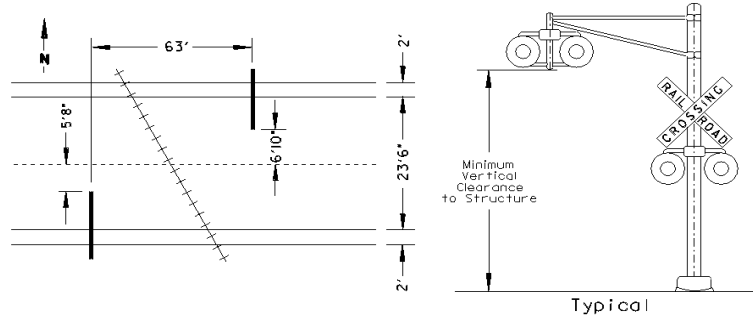

		US 14 E	415.72	E of Volga Eastbound Lane	Cantilever RR Signal	17' 4"	
		US 14 W	415.72	E of Volga Westbound Lane	Cantilever RR Signal	16' 10"	

Hwy 14-East of Volga

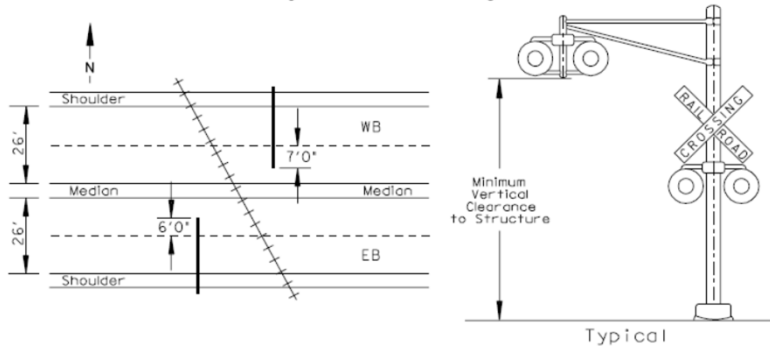

		US 16 N	37.51	3.3 mi South of Hill City and 0.1 mi South Jct SD 87S	Cantilever Hwy Sign	18' 4"	
--	--	---------	-------	---	---------------------	--------	--

Secondary Structure	Structure Controlling Height	Hwy Number	MRM	Location	Structure Type	Maximum Permit Clearance	By-pass ?
		US 16 S	37.66	3.2 mi South of Hill City and 0.0 mi South Jct SD 87S	Cantilever Hwy Sign	18' 2"	
		US 16 N	37.72	3.1 mi South of Hill City and 0.1 mi North Jct SD 87S	Hwy Sign Bridge	18' 4"	
		US 16 S	37.72	3.1 mi South of Hill City and 0.1 mi North Jct SD 87S	Hwy Sign Bridge	19' 2"	
		US 16 N	37.77	Jct SD 244	Cantilever Hwy Sign	18' 8"	
		US 16 S	37.87	Jct SD 244	Cantilever Hwy Sign	18' 9"	
	52-234-432	US 16	37.95	3 mi South of Hill City and 0.1 mi North Jct SD 244	Railroad Underpass	15' 4"	No
	52-308-411	US 16 E	50.60	Keystone Wye	Interchange	16' 4"	Yes
	52-410-318	US 16 E	67.07	City Street 1.9 mi South Jct SD 44 E	Underpass	20' 3"	No
		US 16 W	51.04	0.44 mi East of Keystone Wye Interchange	Sign Bridge	20' 5"	No
	52-410-318	US 16 W	67.07	City Street 1.9 mi South Jct SD 44 E	Underpass	24' 10"	No
		US 16 A	50.49	6.5 mi South Keystone	Tunnel	10' 9"	No
		US 16 A	53.00	4 mi South Keystone	Tunnel	10' 9"	No
	52-311-454	US 16 A	53.02	4 mi South Keystone Pigtail Bridge	Underpass	12' 6"	No
		US 16 A	53.65	3.3 mi South Keystone	Tunnel	11' 4"	No
52-312-448	52-312-449	US 16 A	54.09	2.8 mi South Keystone Pigtail Bridge	Underpass	9' 7"	No
	52-310-446	US 16 A	54.71	2.2 mi South Keystone Pigtail Bridge	Underpass	20' 7"	No
		US 16 A	57.57	1 mi North Keystone	Tunnel	17' 9"	Yes
52-308-411	52-308-412	US 16A W from US 16 W	59.46	Keystone Wye	Interchange	14' 10"	No
		US 16 B SBL	64.36	0.1 mi East of US 16	Sign Bridge	18' 10"	No

Secondary Structure	Structure Controlling Height	Hwy Number	MRM	Location	Structure Type	Maximum Permit Clearance	By-pass ?
		US 16	68.91	In Rapid City Mt Rushmore Rd	Cantilever RR Signal	16' 11"	

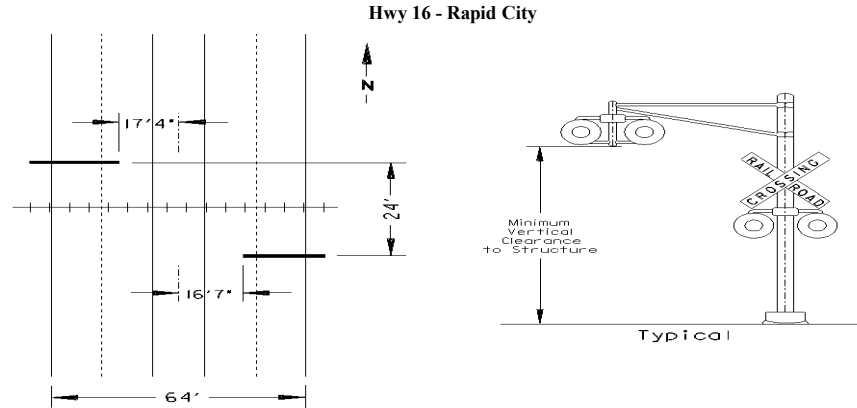

		US 18	374.73	0.5 Miles Northwest of Tripp	Cantilever RR Signals	17' 2"	
--	--	-------	--------	------------------------------	--------------------------	--------	--

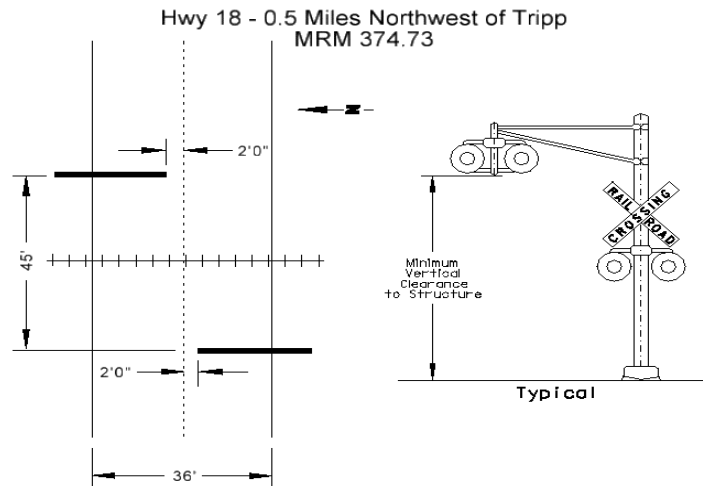

		US 18	447.35	In Canton - East of SD 11	Cantilever RR Signals	17' 2"	
--	--	-------	--------	---------------------------	--------------------------	--------	--

Secondary Structure	Structure Controlling Height	Hwy Number	MRM	Location	Structure Type	Maximum Permit Clearance	By-pass ?
---------------------	------------------------------	------------	-----	----------	----------------	--------------------------	-----------

Hwy 18 - East of SD 11 in Canton
MRM 447.35

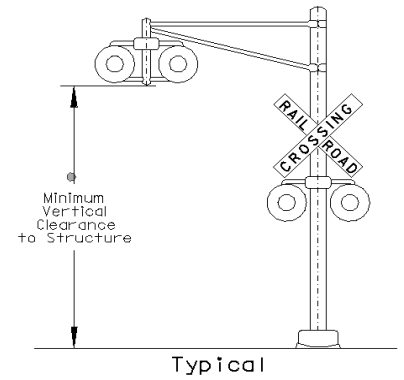
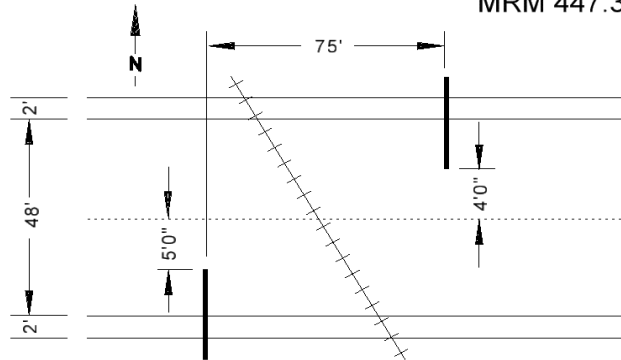

		US 18	448.19	In Canton - 5th St	Cantilever RR Signals	17' 4"	
--	--	-------	--------	--------------------	-----------------------	--------	--

Hwy 18 - 5th Street in Canton
MRM 448.19

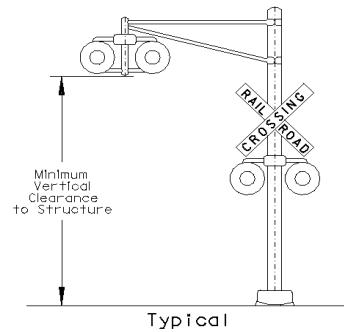
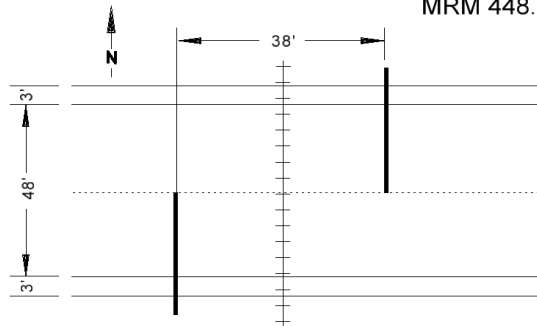

		US 81	1.15	In Yankton - Broadway near 8th St	Cantilever RR Signals	16' 8"	
--	--	-------	------	-----------------------------------	-----------------------	--------	--

Hwy 81 - Near 8th Street in Yankton
MRM 1.12

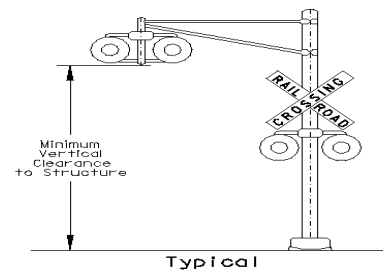
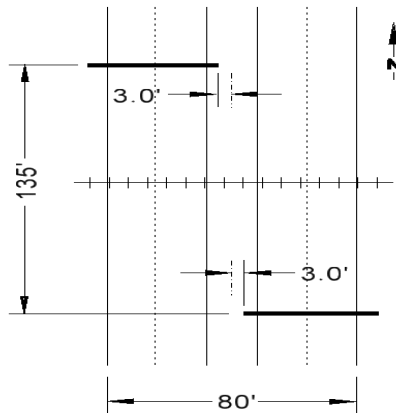

		US 81	119.18	Arlington -N of US 14	Cantilever RR Signals	17' 5"	
--	--	-------	--------	-----------------------	-----------------------	--------	--

Secondary Structure	Structure Controlling Height	Hwy Number	MRM	Location	Structure Type	Maximum Permit Clearance	By-pass ?
---------------------	------------------------------	------------	-----	----------	----------------	--------------------------	-----------

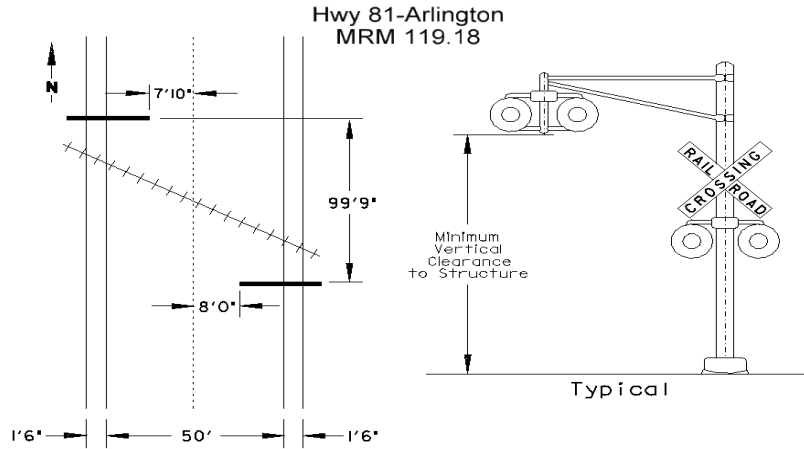

		US 81	156.83	Watertown - N of 5th St	Cantilever RR Signals	16' 11"	
--	--	-------	--------	-------------------------	-----------------------	---------	--

Hwy 81 - Watertown

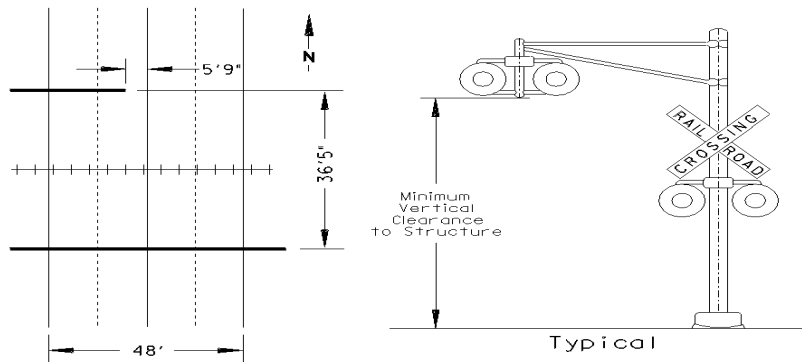

		US 85	55.87	In Belle Fourche - 5th Ave.	Cantilever RR Signal	17' 4"	
--	--	-------	-------	-----------------------------	----------------------	--------	--

Hwy 85 - Belle Fourche

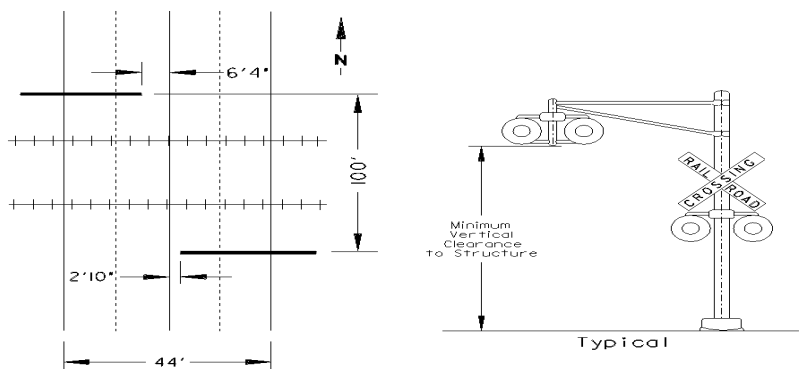

43-160-206	43-160-205	US 183	75.13	Presho Interchange I-90 MRM 226.41	Underpass	15' 5"	No
------------	------------	--------	-------	---------------------------------------	-----------	--------	----

Secondary Structure	Structure Controlling Height	Hwy Number	MRM	Location	Structure Type	Maximum Permit Clearance	By-pass ?
	54-056-158	US 212	208.53	Missouri River at Forest City Actual Width of Bridge is 26'0"	Overhead Truss	17' 0"	No
		US 212	306.52	Redfield - N of W Jct 281	Cantilever RR Signal	17' 0"	

Hwy 212 - Redfield

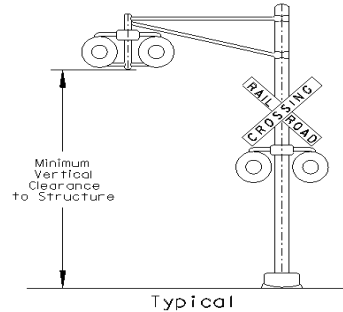
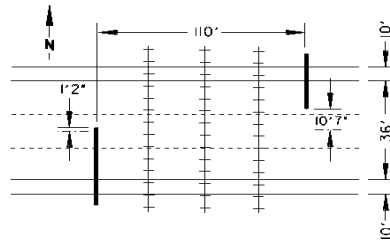

		US 212	307.03	Redfield - E of E Jct 281	Cantilever RR Signal	17' 4"	
--	--	--------	--------	---------------------------	----------------------	--------	--

Hwy 212 - Redfield

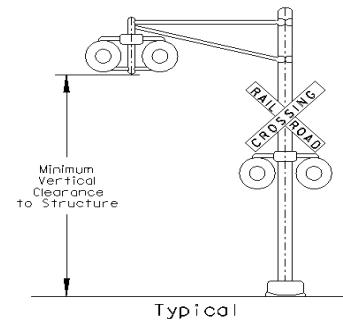
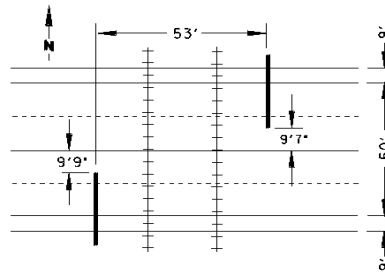

		US 212	376.46	Watertown - E of SD 20	Cantilever RR Signal	17' 11"	
--	--	--------	--------	------------------------	----------------------	---------	--

Hwy 212 - Watertown

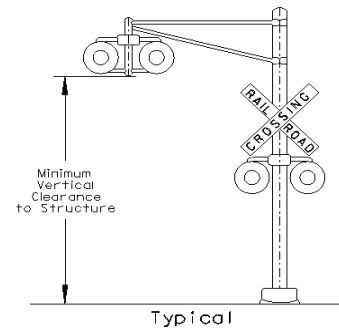
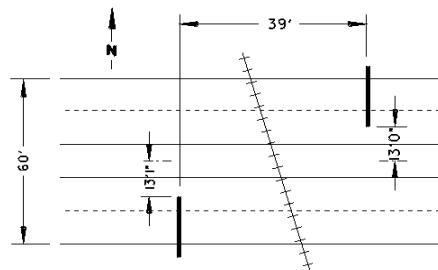

15-214-180	15-215-180	US 212 E	379.75	Watertown Interchange I-29 MRM 177.96	Underpass	16' 8"	No
------------	------------	----------	--------	--	-----------	--------	----

Secondary Structure	Structure Controlling Height	Hwy Number	MRM	Location	Structure Type	Maximum Permit Clearance	By-pass ?
15-214-180	15-215-180	US 212 W	379.75	Watertown Interchange I-29 MRM 177.96	Underpass	16' 3"	No
	07-100-328	US 281	194.47	Aberdeen Mi N Jct Hwy US 12	Overhead Truss	19' 5"	No
		US 385 NB	8.10	South of Oelrichs	Cantilever RR Signal	17' 8"	
		US 385 SB	8.10	South of Oelrichs	Cantilever RR Signal	17' 9"	

US 385 - South of Oelrichs
MRM 8.10

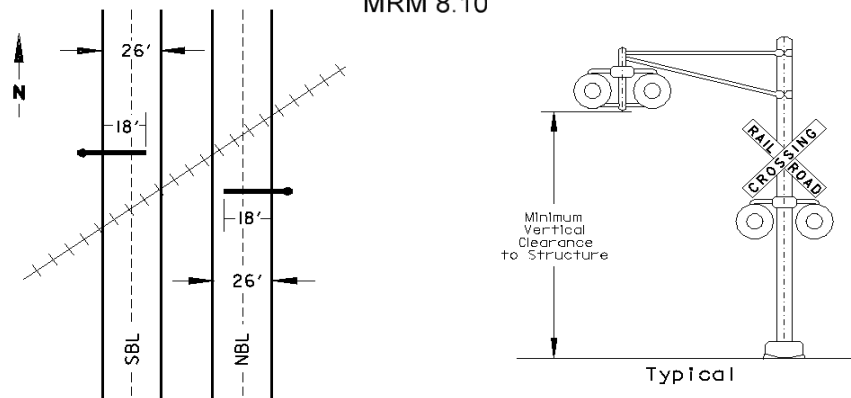

South Dakota Hwys

		SD 10	321.26	In Britton	Cantilever RR Signal	18' 3"	
		SD 10	358.95	In Sisseton	Cantilever RR Signal	18' 1"	
		SD 11	35.06	In Alcester	Cantilever RR Signal	16' 5"	

Hwy 11-Alcester
MRM 35.06

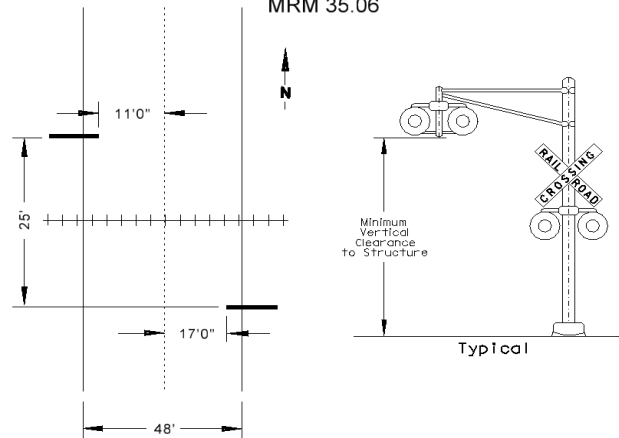

Secondary Structure	Structure Controlling Height	Hwy Number	MRM	Location	Structure Type	Maximum Permit Clearance	By-pass ?
		SD 11	60.36	5 Miles North of US 18	Cantilever RR Signal	17' 5"	

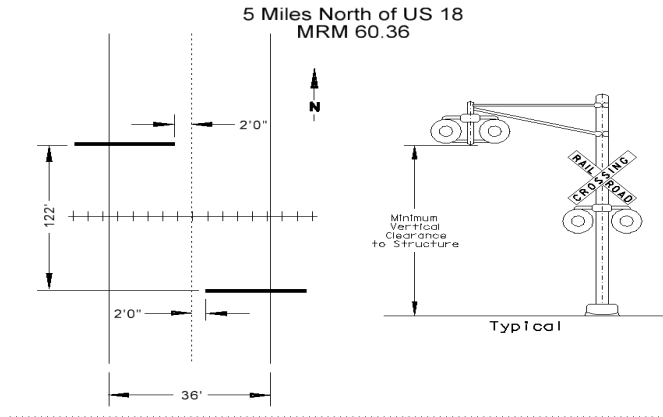

		SD 11	81.56	North edge of Corson	Cantilever RR Signal	17' 10"	
--	--	-------	-------	----------------------	----------------------	---------	--

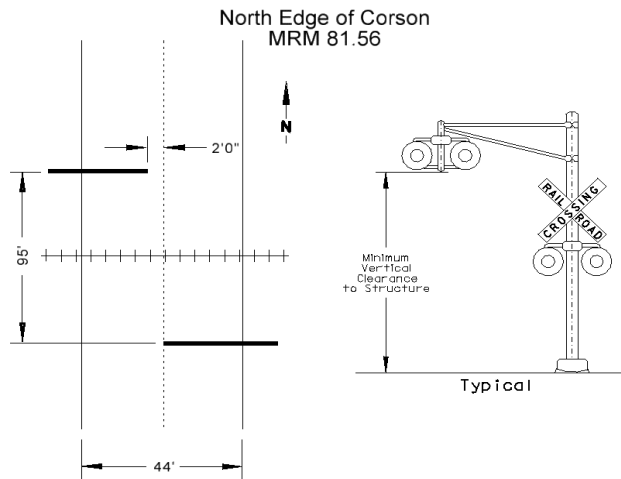

		SD 15	175.23	Milbank - N of US 12	Cantilever RR Signal	17' 9"	
--	--	-------	--------	----------------------	----------------------	--------	--

Secondary Structure	Structure Controlling Height	Hwy Number	MRM	Location	Structure Type	Maximum Permit Clearance	By-pass ?
---------------------	------------------------------	------------	-----	----------	----------------	--------------------------	-----------

Hwy 15 - Milbank

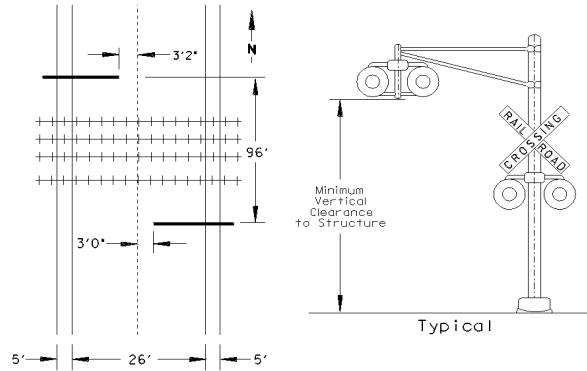

		Former SD 16 T		East North St. In Rapid City 0.1 mi South of I-90	Cantilever RR Signal	18' 0"	
--	--	----------------	--	---	----------------------	--------	--

Hwy 16T - Rapid City

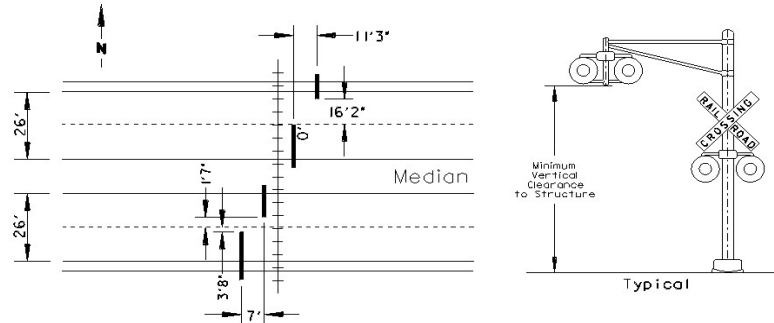

52-435-288	52-435-289	SD 16 T	72.09	I-90 - SD 16T Interchange I-90 MRM 60.48	Interchange	16' 10"	No
		SD 17	42.76	East edge of Lennox	Cantilever RR Signal	19' 9"	

Hwy 17 - East edge of Lennox
MRM 42.76

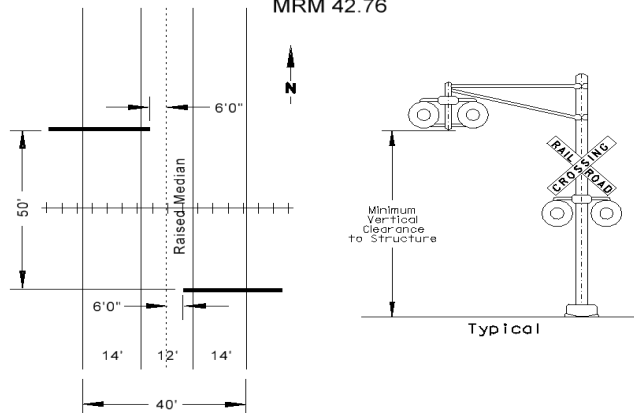

Secondary Structure	Structure Controlling Height	Hwy Number	MRM	Location	Structure Type	Maximum Permit Clearance	By-pass ?
50-020-142	50-020-141	SD 19	72.48	SD 19 - I-90 Interchange I-90 MRM 379.66	Underpass	14' 8"	No
		SD 20	443.50	Near LaBolt - North of SD 15/SD 20 south Jct.	Cantilever RR Signal	20' 1"	No
29-299-040	29-300-040	SD 22	360.64	SD 22 - I-29 Interchange I-29 MRM 164.58	Underpass	15' 8"	No
		SD 25	115.15	DeSmet - N of US 14	Cantilever RR Signal	17' 5"	

Hwy 25 - DeSmet

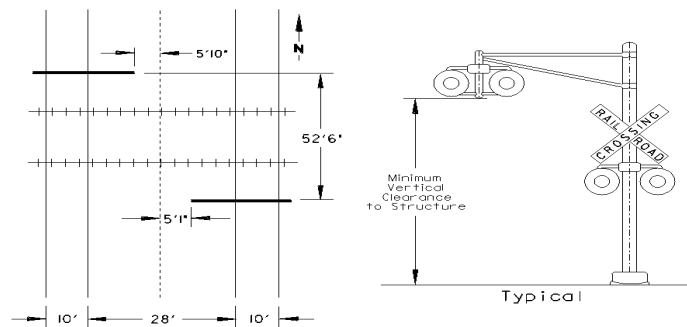

		SD 25	181.42	Webster - Main St	Cantilever RR Signal	17' 10"	
--	--	-------	--------	-------------------	-------------------------	---------	--

Hwy 25 - Webster

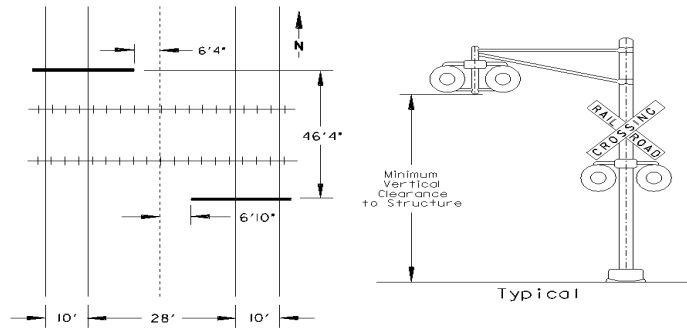

		SD 27	230.61	In Britton	Cantilever RR Signal	17' 4"	
		SD 34	25.61	Northwest of Whitewood	Cantilever RR Signal	17' 7"	

Secondary Structure	Structure Controlling Height	Hwy Number	MRM	Location	Structure Type	Maximum Permit Clearance	By-pass ?
---------------------	------------------------------	------------	-----	----------	----------------	--------------------------	-----------

Hwy 34-Whitewood

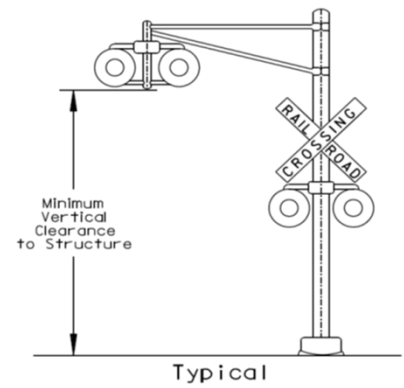
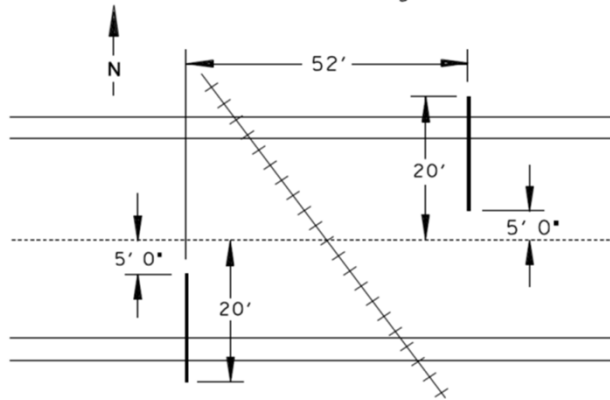

		SD 34	327.72	In Woonsocket	Cantilever RR Signal	16' 7"	
--	--	-------	--------	---------------	----------------------	--------	--

Hwy 34 - In Woonsocket
MRM 327.72

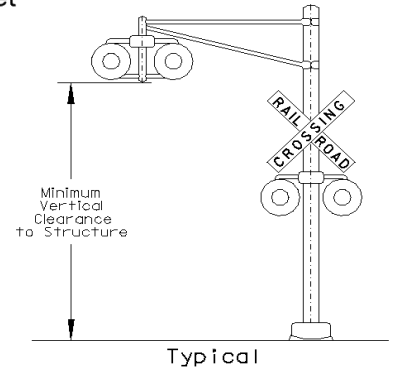
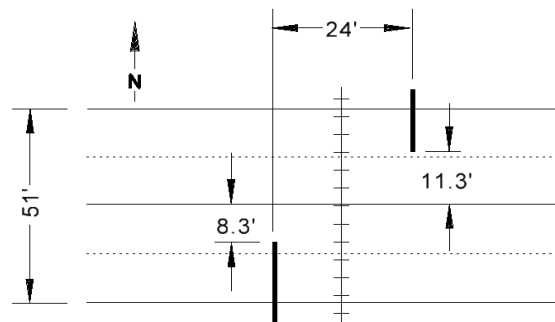

		SD 34	387.46	In Madison	Cantilever RR Signal	17' 4"	
--	--	-------	--------	------------	----------------------	--------	--

Hwy 34 - In Madison
MRM 387.46

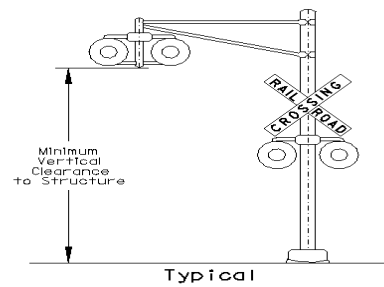
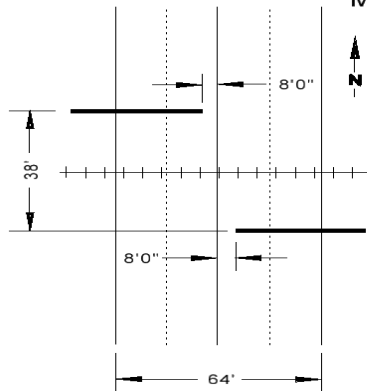

18-157-108	18-157-107	SD 37 N	72.97	Mitchell Interchange I-90 MRM 332.19	Underpass	16' 0"	No
------------	------------	---------	-------	---	-----------	--------	----

Secondary Structure	Structure Controlling Height	Hwy Number	MRM	Location	Structure Type	Maximum Permit Clearance	By-pass ?
18-157-108	18-157-107	SD 37 S	72.97	Mitchell Interchange I-90 MRM 332.19	Underpass	16' 0"	No

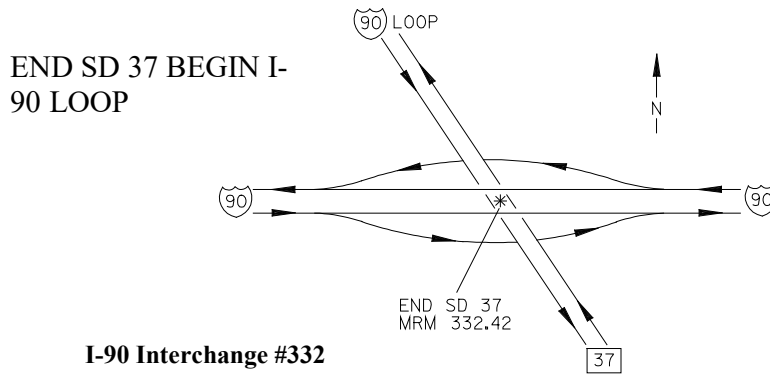

- Trucks traveling on SD 37 North that need to go onto I-90 West also travel on I-90 Loop North for a short distance.
- Trucks traveling on I-90 Loop South that need to go onto I-90 East also travel on SD 37 South for a short distance.

		SD 37	74.27	In Mitchell, Truck By-Pass	Cantilever RR Signal	17' 7"	
--	--	-------	-------	----------------------------	-------------------------	--------	--

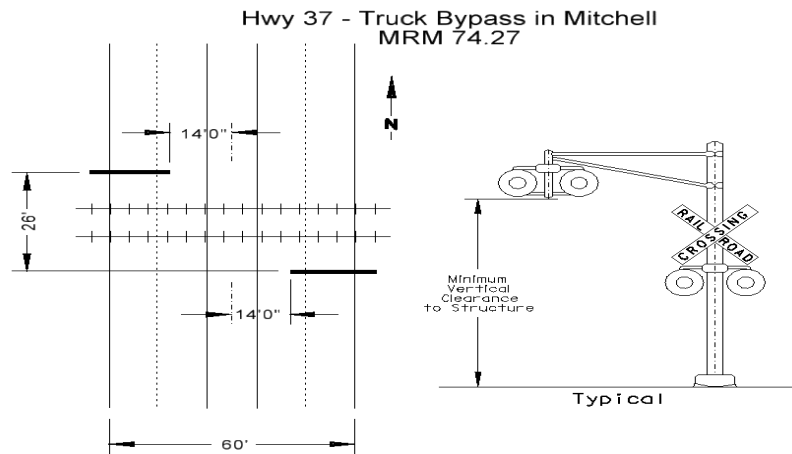

		SD 37 N	75.83	SD 37 Bypass & Minnesota Street in Mitchell	Cantilever Mast Arm/Lights	17' 2"	
		SD 37 S	75.83	SD 37 Bypass & Minnesota Street in Mitchell	Cantilever Mast Arm/Lights	18' 5"	
		SD 37	127.45	Huron - Dakota Ave	Cantilever RR Signal	17' 7"	

Secondary Structure	Structure Controlling Height	Hwy Number	MRM	Location	Structure Type	Maximum Permit Clearance	By-pass ?
---------------------	------------------------------	------------	-----	----------	----------------	--------------------------	-----------

Hwy 37 - Huron

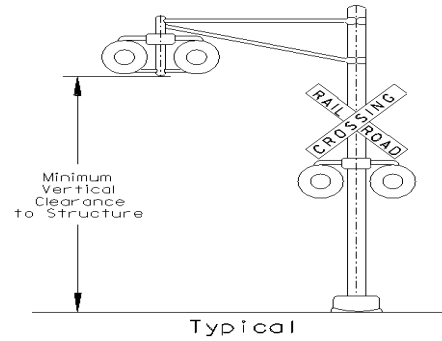
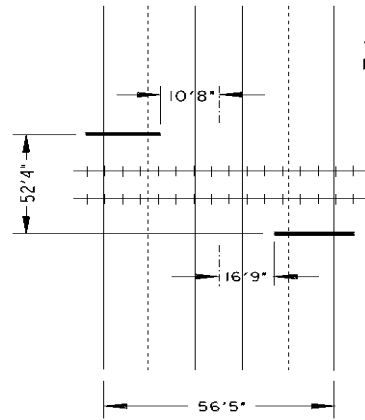

		SD 37	128.21	Huron - Dakota Ave	Cantilever RR Signal	17' 9"	
--	--	-------	--------	--------------------	----------------------	--------	--

Hwy 37 - Huron

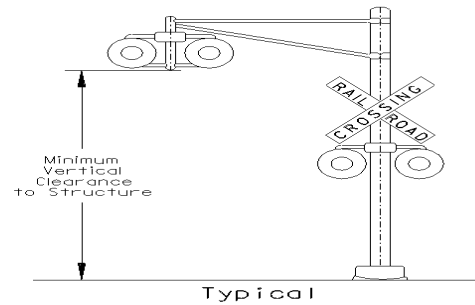
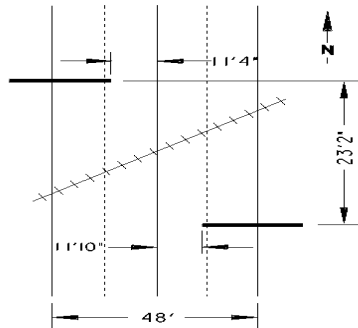

		SD 37	207.59	Groton - S of US 12	Cantilever RR Signal	17' 8"	
--	--	-------	--------	---------------------	----------------------	--------	--

Hwy 37 - Groton

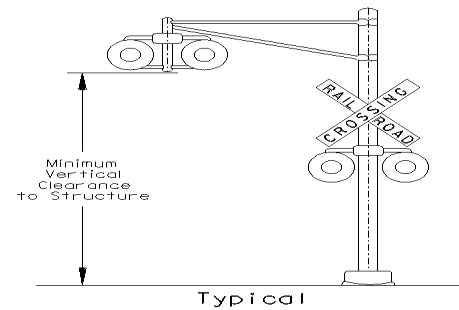
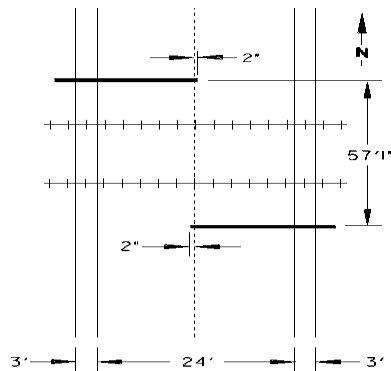

		SD 38	300.49	In Mitchell - E. of Burr	Cantilever RR Signal	17' 10"	
--	--	-------	--------	--------------------------	----------------------	---------	--

Secondary Structure	Structure Controlling Height	Hwy Number	MRM	Location	Structure Type	Maximum Permit Clearance	By-pass ?
---------------------	------------------------------	------------	-----	----------	----------------	--------------------------	-----------

Hwy 38 - East of Burr Street in Mitchell
MRM 300.49

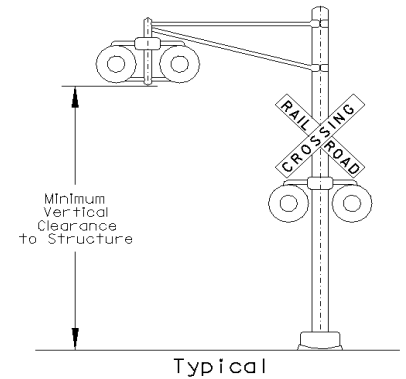
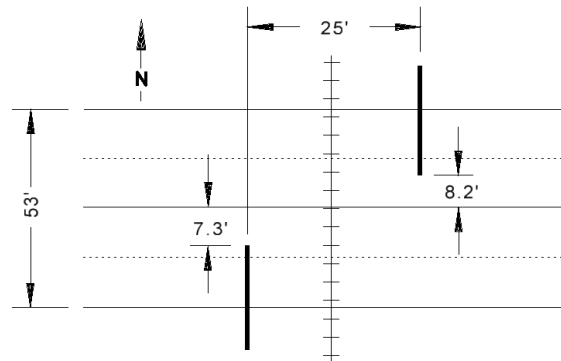

31-010-106	31-010-107	SD 38 Spur	304.42	I-90 MRM 335.43 4 mi East Mitchell	Underpass	14' 9"	No
50-119-165	50-119-166	SD 38	359.44	Sioux Falls Interchange I-90 MRM 390.28	Underpass	16' 0"	No
		SD 44	43.92	In Rapid City - Mt View Rd	Cantilever RR Signal	17' 0"	

Hwy 44-Rapid City

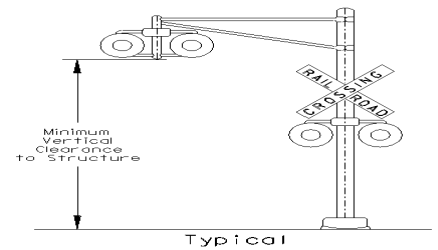
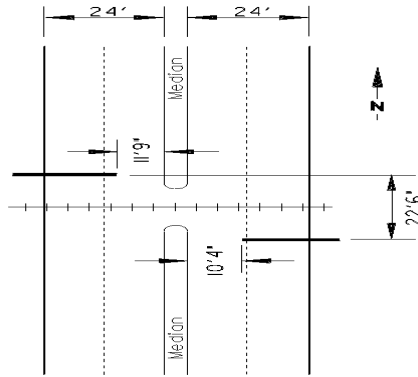

		SD 44 E	44.88	In Rapid City - Omaha St	Sign Bridge	25' 6"	
		SD 44 W	44.88	In Rapid City - Omaha St	Sign Bridge	25' 8"	
		SD 44 E	44.95	In Rapid City - Omaha St	Cantilever Hwy Sign	18' 9"	
		SD 44	45.53	In Rapid City - Omaha St	Cantilever RR Signal	17' 5"	

Secondary Structure	Structure Controlling Height	Hwy Number	MRM	Location	Structure Type	Maximum Permit Clearance	By-pass ?
---------------------	------------------------------	------------	-----	----------	----------------	--------------------------	-----------

Hwy 44 - Rapid City

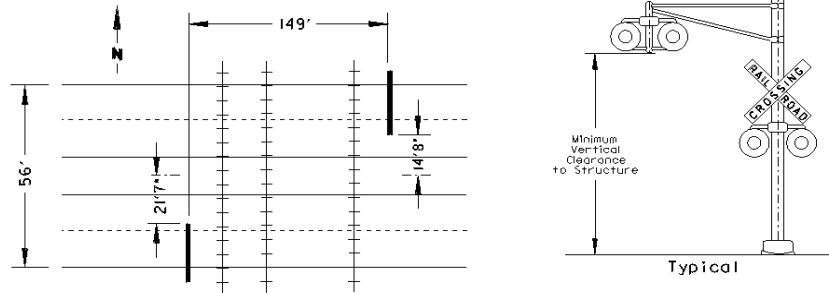

		SD 44	45.57	In Rapid City - Omaha St	Cantilever RR Signal	17' 6"	
--	--	-------	-------	--------------------------	----------------------	--------	--

Hwy 44 - Rapid City

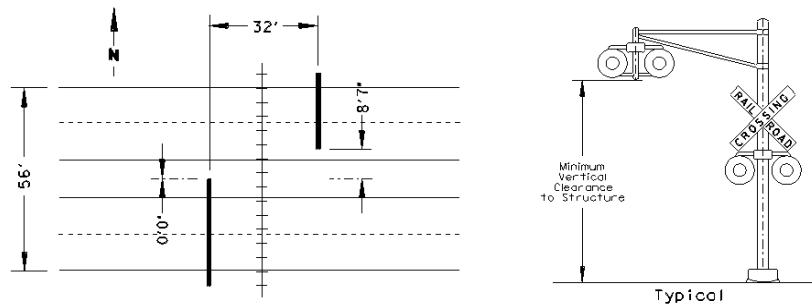

	52-446-311	SD 44 E	48.92	In Rapid City - US 16B	Underpass	18' 8"	No
	52-446-311	SD 44 W	48.92	In Rapid City - US 16B	Underpass	18' 7"	No
	004403932RR0B	SD 44	393.32	0.52 miles SE of SD 44/SD 19 Jct. in Parker - 125' Long. Offset	Cantilever RR Signal	17' 8"	

Hwy 44/Hwy 19 - .52 Miles SE of Parker
MRM 393.32

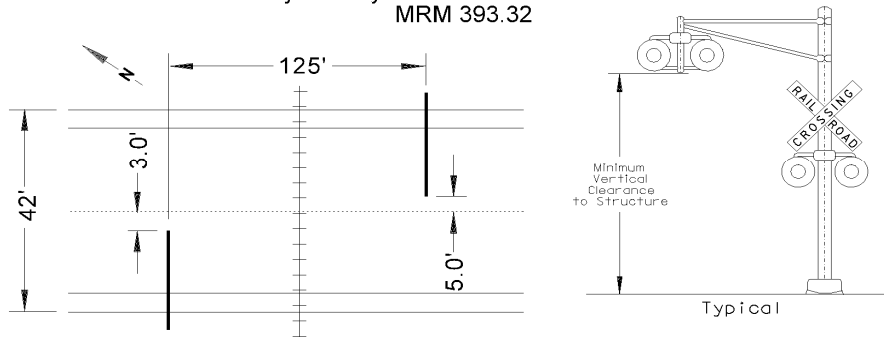

08-258-136	08-258-135	SD 45	56.80	Kimball Interchange I-90 MRM 284.06	Underpass	15' 0"	No
------------	------------	-------	-------	-------------------------------------	-----------	--------	----

Secondary Structure	Structure Controlling Height	Hwy Number	MRM	Location	Structure Type	Maximum Permit Clearance	By-pass ?
		SD 45	111.33	Miller - S of Jct US 14	Cantilever RR Signal	17' 7"	

Hwy 45 - Miller

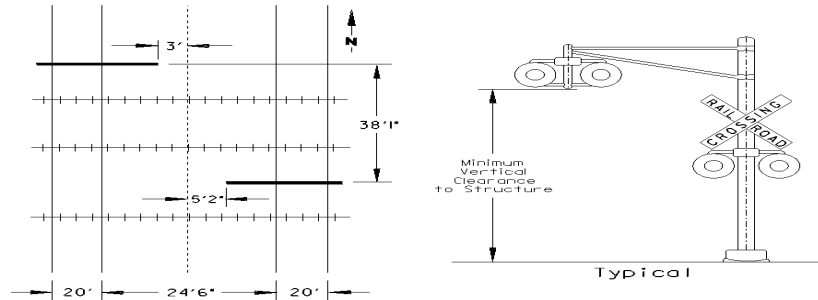

		SD 45	177.33	Ipswich	Cantilever RR Signal	17' 3"	
--	--	-------	--------	---------	----------------------	--------	--

SD Highway 45 - Ipswich
MRM 177.33

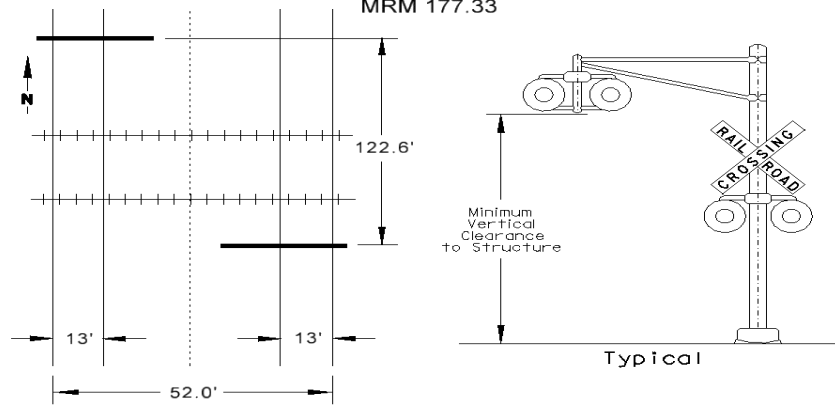

		SD 46	320.82	East of SD 25	Cantilever RR Signal	17' 7"	
--	--	-------	--------	---------------	----------------------	--------	--

Hwy 34 - 2.5 Miles East of SD 25
MRM 320.82

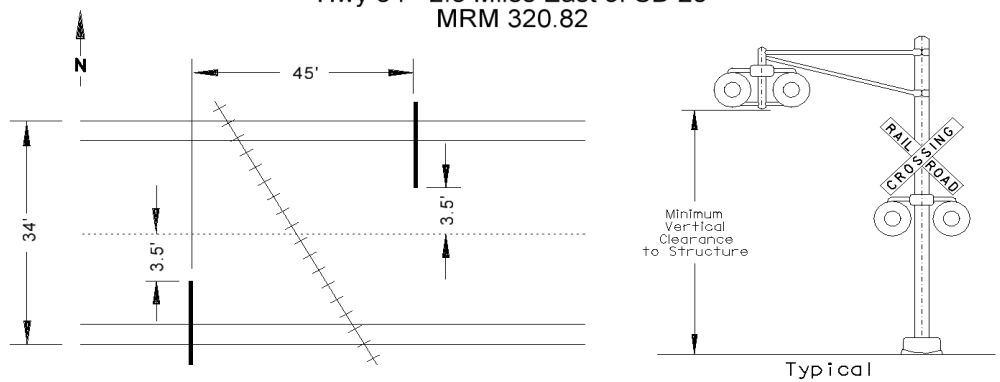

		SD 46	366.29	In Beresford	Cantilever RR Signal	17' 8"	
--	--	-------	--------	--------------	----------------------	--------	--

Secondary Structure	Structure Controlling Height	Hwy Number	MRM	Location	Structure Type	Maximum Permit Clearance	By-pass ?
---------------------	------------------------------	------------	-----	----------	----------------	--------------------------	-----------

Hwy 46 - In Beresford
MRM 447.35

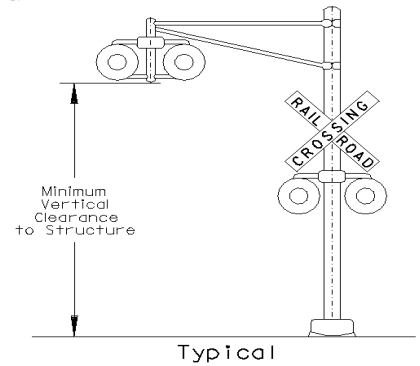
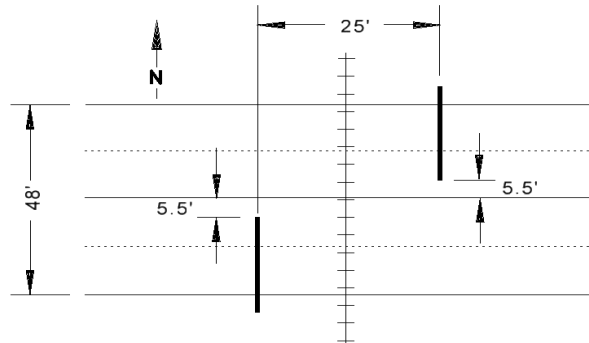

43-401-237	43-401-238	SD 47	67.76	I-90 - SD 47 Interchange I-90 MRM 251.09	Underpass	15' 9"	No
------------	------------	-------	-------	---	-----------	--------	----

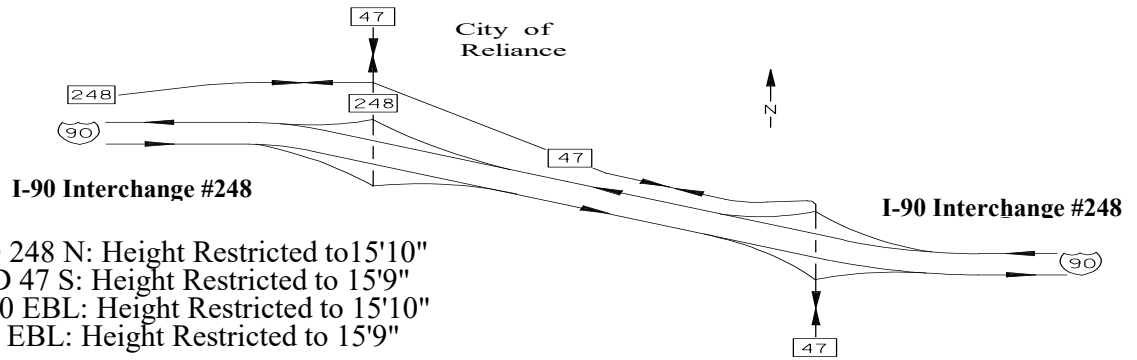

		SD 50	381.63	N. of Yankton	Cantilever RR Signal	17' 0"	
--	--	-------	--------	---------------	----------------------	--------	--

Hwy 50 - 1.0 Miles West of US 81
MRM 381.63

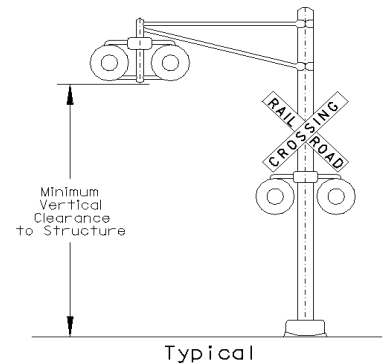
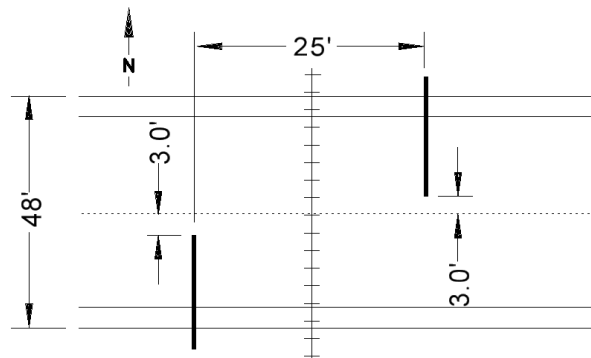

	14-131-205	SD 50 E Loop	411.25	Under SD 50 E East Vermillion	Underpass	16' 4"	No
	14-092-199	SD 50 W Loop	407.10	Under SD 50 2 mi NW Vermillion	Underpass	22' 11"	No

Secondary Structure	Structure Controlling Height	Hwy Number	MRM	Location	Structure Type	Maximum Permit Clearance	By-pass ?
	14-131-205	SD 50 W Loop	411.25	Under SD 50 E East Vermillion	Underpass	15' 10"	No
		SD 50	416.70	0.1 mi West of I-29/SD50 Interchange	Sign Bridge	16' 11"	No
36-436-105	36-436-106	SD 63	76.31	I-90 - SD 63S Interchange I-90 MRM 163.04	Underpass	14' 7"	No
36-501-078	36-501-079	SD 63	83.47	I-90 - SD 63N Interchange I-90 MRM 170.32	Underpass	14' 9"	No
		SD 63	96.67	In Midland	Cantilever RR Signal	17' 6"	

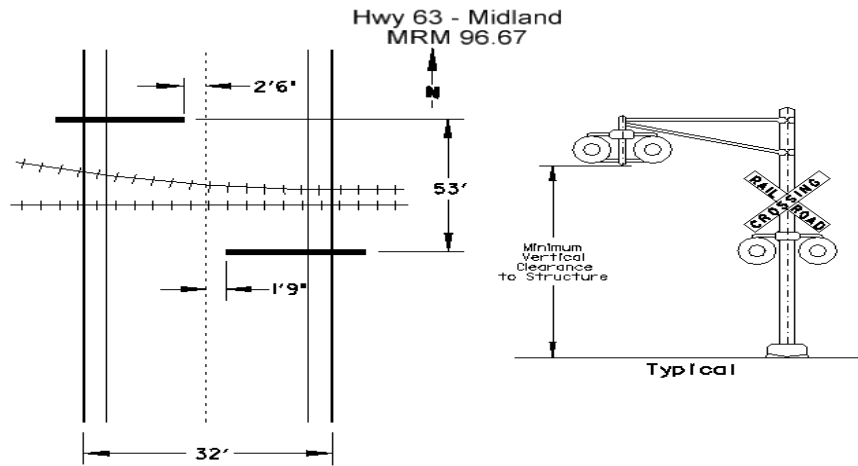

		SD 63	251.81	In McLaughlin	Cantilever RR Signal	17' 6"	
--	--	-------	--------	---------------	----------------------	--------	--

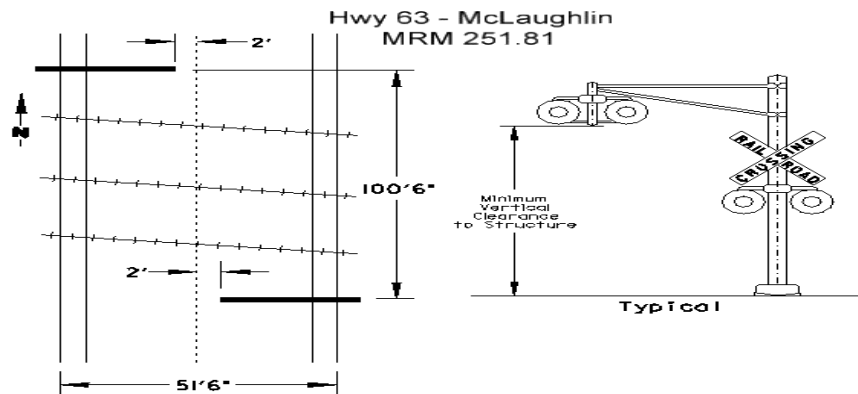

36-240-110	36-240-111	SD 73	78.18	I-90 - SD 73N Interchange I-90 MRM 143.30	Underpass	15' 0"	No
		SD 73	92.36	In Philip	Cantilever RR Signal	17' 6"	

Secondary Structure	Structure Controlling Height	Hwy Number	MRM	Location	Structure Type	Maximum Permit Clearance	By-pass ?
---------------------	------------------------------	------------	-----	----------	----------------	--------------------------	-----------

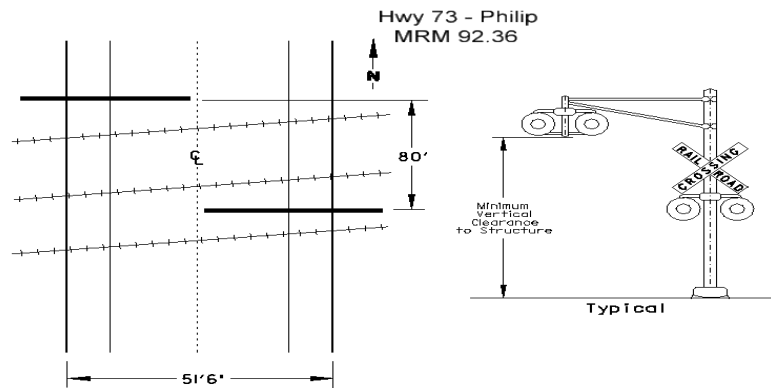

	52-430-330	SD 79 N	74.55	In Rapid City US 16B - SD 79 Interchange	Interchange	16' 10"	No
	52-430-330	SD 79 S	74.55	In Rapid City US 16B - SD 79 Interchange	Interchange	16' 10"	No
	17-284-185	SD 87	43.01	Under SD 87 Pigtail Bridge	Underpass	16' 4"	No
		SD 87	66.85	6 mi SE Sylvan Lake	Tunnel	10' 10"	No
		SD 87	72.00	2 mi SE Sylvan Lake	Tunnel	9' 9"	No
		SD 87	74.65	1 mi North Sylvan Lake	Tunnel	9' 8"	No
		SD 115	68.98	1.5 Miles North of US 18	Cantilever RR Signal	17' 6"	

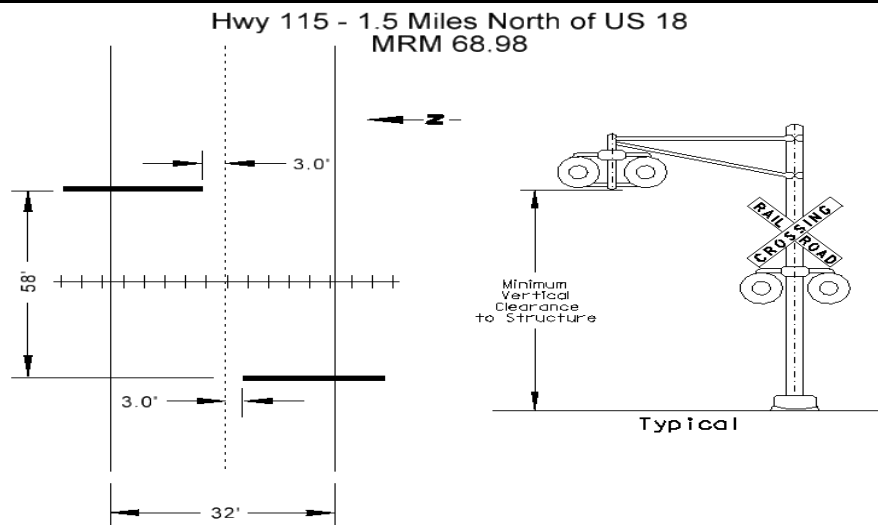

50-200-233	50-201-233	SD 115 N	81.95	Minnesota Ave Interchange I-229 MRM 3.12	Underpass	15' 10"	No
------------	------------	----------	-------	---	-----------	---------	----

Secondary Structure	Structure Controlling Height	Hwy Number	MRM	Location	Structure Type	Maximum Permit Clearance	By-pass ?
50-200-233	50-201-233	SD 115 S	81.95	Minnesota Ave Interchange I-229 MRM 3.12	Underpass	15' 10"	No
50-210-167	50-210-168	SD 115 N	89.07	I-90 - SD 115 Interchange I-90 MRM 399.56	Underpass	18' 1"	No
50-210-167	50-210-168	SD 115 S	89.07	I-90 - SD 115 Interchange I-90 MRM 399.56	Underpass	18' 1"	No
		SD 115	104.30	In Dell Rapids	Cantilever RR Signal	17' 9"	

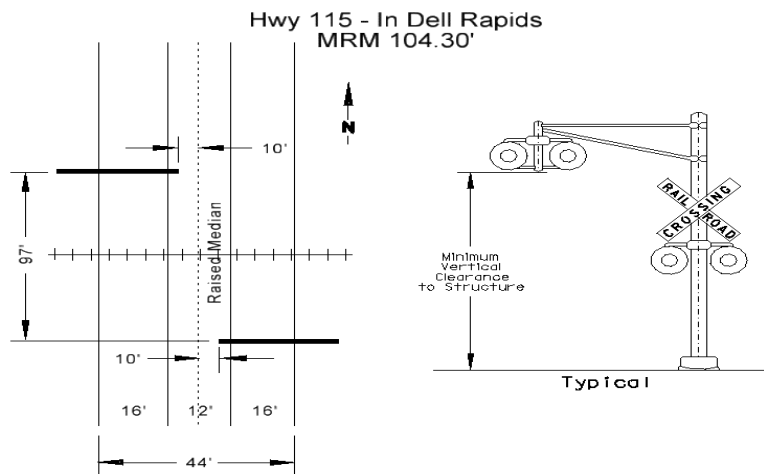

55-176-060	55-175-060	SD 127	234.38	I-29 - SD 127 Interchange I-29 MRM 246.44	Underpass	15' 10"	No
		Former SD 230		In Rapid City - Elgin St	Cantilever RR Signal	17' 1"	

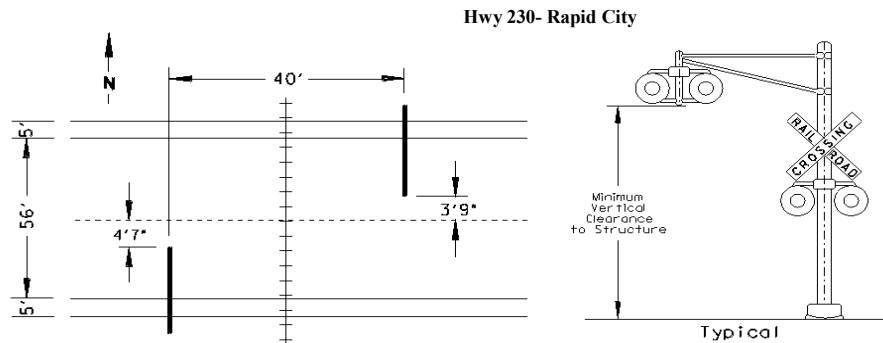

		SD 231	86.20	In Black Hawk Peaceful Pines Rd.	Cantilever RR Signal	17' 0"	
--	--	--------	-------	-------------------------------------	-------------------------	--------	--

Secondary Structure	Structure Controlling Height	Hwy Number	MRM	Location	Structure Type	Maximum Permit Clearance	By-pass ?
---------------------	------------------------------	------------	-----	----------	----------------	--------------------------	-----------

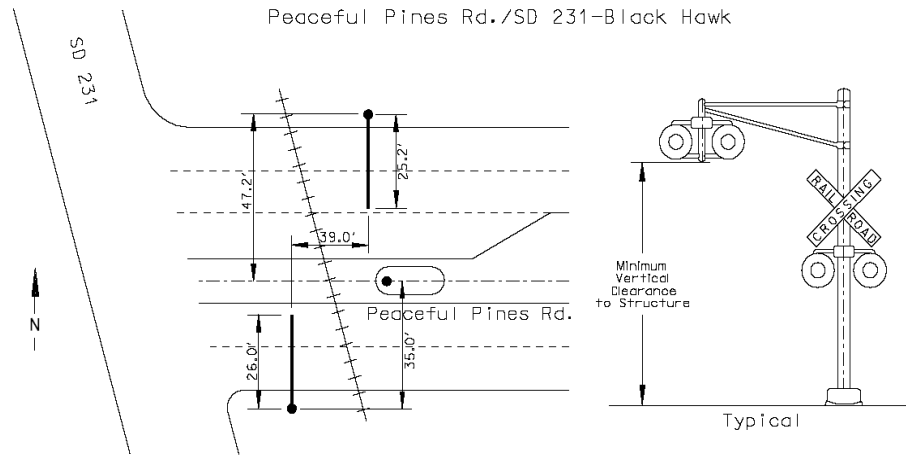

52-910-366	52-910-365	SD 240	127.47	Wall Interchange I-90 MRM 110.98	Underpass	14' 4"	No
		SD 247	169.57	Roscoe - Main St	Cantilever RR Signal	17' 4"	

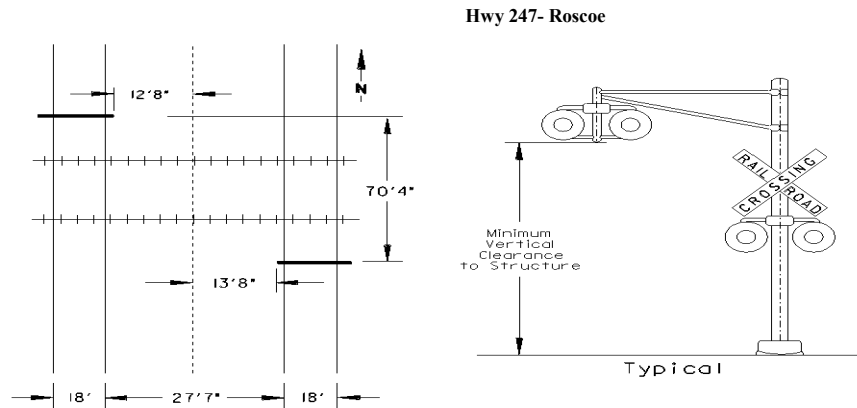

43-380-227	43-380-228	SD 248	262.52	Reliance Interchange I-90 MRM 248.79	Underpass	15' 8"	No
36-330-100	36-330-101	SD 248 Spur	164.80	2.2 mi East SD 73S I-90 MRM 152.42	Underpass	14' 8"	No
	65-290-057	SD 271	167.65	1.1 mi NE Jct SD 130	Railroad Underpass	11' 10"	No
43-250-206	43-250-207	SD 273	61.31	Kennebec Interchange I-90 MRM 235.43	Underpass	16' 0"	No

Secondary Structure	Structure Controlling Height	Hwy Number	MRM	Location	Structure Type	Maximum Permit Clearance	By-pass ?
Miscellaneous Roads Under I-29							
64-154-385	64-155-385	River Drive	I-29 MRM 2.48	North Sioux City Interchange (old SD 105)	Underpass	16' 2"	No
64-006-050	64-005-050	County Road	I-29 MRM 42.31	Interchange # 42	Interchange	15' 3"	No
42-065-030	42-064-030	County Road	I-29 MRM 73.38	Interchange # 73 (Tea)	Interchange	16' 10"	Yes
50-176-210	50-175-210	SD 42 (W. 12 th St.)	I-29 MRM 79.29	Interchange # 79	Interchange	16' 1"	Yes
50-178-199	50-177-199	Madison Street	I-29 S MRM 80.29	1 mi N of SD 42 Interchange	Interchange	16' 3"	No
50-181-180	50-180-180	Benson Road	I-29 MRM 82.41	1.0 mi S of SD38 Interchange	Interchange	16' 11"	Yes
	50-179-191	On Ramp	I-29 MRM 82.41	West Bound Russell St to 29 NB	Underpass	17' 4"	No
50-176-100	50-175-100	County Road	I-29 MRM 90.49	4 mi North Interchange # 86	Underpass	13' 3"	No
50-176-060	50-175-060	County Road	I-29 MRM 94.49	Interchange # 94 (Baltic)	Interchange	14' 7"	No
50-175-010	50-176-010	County Road	I-29 MRM 99.49	1 mi North Interchange # 98	Underpass	14' 6"	No
51-066-230	51-065-230	County Road	I-29 MRM 101.81	4.3 mi North Interchange # 98	Underpass	14' 6"	No
51-066-180	51-065-180	County Road	I-29 MRM 106.83	3 mi South Interchange # 109	Underpass	14' 3"	No
51-065-130	51-066-130	County Road	I-29 MRM 111.84	2 mi North Interchange # 109	Underpass	13' 1"	No
51-066-120	51-065-120	County Road	I-29 MRM 112.83	2 mi South Interchange # 114	Underpass	13' 4"	No
51-066-080	51-065-080	County Road	I-29 MRM 116.84	2 mi North Interchange # 114	Underpass	14' 11"	No
51-066-030	51-065-030	County Road	I-29 MRM 121.83	Interchange # 121 (Ward)	Interchange	14' 4"	No
06-185-169	06-184-169	Other Road	I-29 MRM 131.89	0.9 mi South Interchange # 132	Underpass	17' 8"	No
06-184-050	06-185-050	County Road	I-29 MRM 143.80	3 mi North Interchange # 140	Underpass	14' 6"	No
06-184-010	06-185-010	County Road	I-29 MRM 147.80	3 mi South Interchange # 150	Underpass	14' 9"	No
20-050-248	20-049-248	County Road	I-29 MRM 154.50	3.6 mi NW Interchange # 150	Underpass	14' 8"	No

Secondary Structure	Structure Controlling Height	Hwy Number	MRM	Location	Structure Type	Maximum Permit Clearance	By-pass ?
20-035-220	20-034-220	County Road		I-29 MRM 157.63 Interchange # 157 (Brandt)	Interchange	14' 9"	No
20-030-211	20-029-211	County Road		I-29 MRM 158.74 1 mi North Interchange # 157	Underpass	14' 9"	No
20-027-207	20-028-207	Other Road		I-29 MRM 159.16 5.5 mi South Interchange # 164	Underpass	15' 11"	No
20-015-180	20-014-180	County Road		I-29 MRM 162.15 2.5 mi South Interchange # 164	Underpass	14' 7"	No
29-260-000	29-261-000	County Road		I-29 MRM 170.23 5.5 mi NW Interchange # 164	Underpass	15' 10"	No
15-220-200	15-220-199	County Road		I-29 MRM 175.93 2 mi SE Interchange # 177	Underpass	14' 9"	No
15-215-100	15-216-100	County Road		I-29 MRM 185.95 Interchange # 185 (Waverly)	Interchange	15' 0"	No
26-086-100	26-085-100	County Road		I-29 MRM 197.96 3 mi South Interchange # 201	Underpass	15' 2"	No
26-086-070	26-085-070	County Road		I-29 MRM 201.05 Interchange # 201	Interchange	14' 10"	No
26-085-040	26-084-040	County Road		I-29 MRM 204.06 3 mi North Interchange # 201	Underpass	14' 11"	No
55-090-380	55-089-380	County Road		I-29 MRM 212.24 1.6 mi South Interchange # 213	Underpass	15' 0"	No
55-108-350	55-109-350	County Road		I-29 MRM 215.79 2 mi North Interchange # 213	Underpass	14' 9"	No
55-116-270	55-115-270	County Road		I-29 MRM 224.02 Interchange # 224 (Peever)	Interchange	15' 7"	No
55-115-241	55-114-241	County Road		I-29 MRM 226.84 2 mi North Interchange # 224	Underpass	14' 7"	No
55-160-100	55-161-100	County Road		I-29 MRM 242.02 Interchange # 242	Interchange	15' 2"	No
55-181-010	55-180-010	County Road		I-29 MRM 251.50 1 mi South North Dakota Line	Underpass	15' 1"	No
Miscellaneous Roads Under I-90							
41-020-041	41-020-042	County Road		I-90 MRM 2.25 Interchange # 2	Interchange	15' 1"	No
41-061-056	41-061-057	County Road		I-90 MRM 7.02 3 mi West Interchange # 10	Underpass	16' 0"	No
41-080-057	41-080-058	County Road		I-90 MRM 8.96 1.3 mi West Interchange # 10	Underpass	15' 2"	No
41-110-085	41-110-086	County Road		I-90 MRM 13.61 0.8 mi West Interchange # 14	Underpass	15' 8"	No

Secondary Structure	Structure Controlling Height	Hwy Number	MRM	Location	Structure Type	Maximum Permit Clearance	By-pass ?
41-140-088	41-140-089	County Road		I-90 MRM 16.67 1.5 mi West Interchange # 17	Underpass	14' 7"	No
41-160-084	41-160-083	County Road		I-90 MRM 18.84 0.7 mi West Interchange # 17	Underpass	14' 11"	No
47-024-439	47-024-438	County Road		I-90 MRM 31.50 0.9 mi NW Interchange # 32	Underpass	23' 11"	No
47-030-444	47-030-443	County Road		I-90 MRM 32.27 0.1 mi NW Interchange # 32	Underpass	23' 10"	No
47-033-444	47-033-445	County Road		Sturgis Interchange I-90 MRM 32.41	Interchange	16' 6"	No

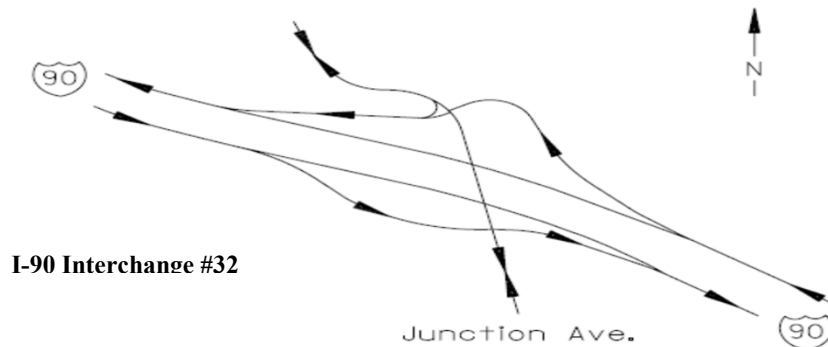

47-048-461	47-048-462	Frontage Road		I-90 MRM 34.81 Inter. # 34 (BH Cemetery)	Interchange	15' 10"	No
47-088-550	47-088-551	County Road		I-90 MRM 44.66 Interchange # 44 (Piedmont)	Interchange	16' 5"	No
52-415-286	52-415-285	Haines Ave		I-90 MRM 58.30 Interchange # 58 (Haines Ave)	Interchange	17' 8"	No
52-420-285	52-420-286	N Maple Ave		I-90 MRM 58.80 0.5 mi East Interchange # 58	Underpass	14' 7"	No
52-435-288	52-435-289	East North Street		I-90 MRM 60.48 Interchange # 60	Underpass	16' 10"	No
52-485-275	52-485-276	County Road		I-90 MRM 65.69 0.5 mi West Interchange # 66	Underpass	35' 4"	No
52-490-276	52-490-275	EAFB Main Ent.		I-90 MRM 66.17 Box Elder Interchange S. Ellsworth Rd.	Underpass	14' 11"	No
52-510-274	52-510-275	County Road		I-90 MRM 68.15 - 1 Mile East of Exit 67	Underpass	19' 0"	No
52-580-285	52-580-284	County Road		I-90 MRM 75.31 3 mi West Interchange # 78	Underpass	14' 3"	No
52-690-286	52-690-285	County Road		I-90 MRM 86.23 2 mi East Interchange # 84	Underpass	14' 7"	No

Secondary Structure	Structure Controlling Height	Hwy Number	MRM	Location	Structure Type	Maximum Permit Clearance	By-pass ?
52-730-285	52-730-286	County Road		I-90 MRM 90.25 Interchange # 90 (Wicksville)	Interchange	13' 10"	No
52-750-285	52-750-284	County Road		I-90 MRM 92.23 2 mi East Interchange # 90	Underpass	13' 3"	No
52-800-311	52-800-310	County Road		I-90 MRM 98.14 Interchange # 99 (Wasta)	Interchange	24' 11"	No
52-954-400	52-953-400	County Road		I-90 MRM 116.94 Interchange # 116	Interchange	15' 7"	No
52-A00-420	52-A00-419	County Road		I-90 MRM 121.98 Interchange # 121	Interchange	15' 8"	No
36-090-088	36-090-087	County Road		I-90 MRM 127.73 Interchange # 127	Interchange	15' 6"	No
36-170-110	36-170-111	County Road		I-90 MRM 136.35 5 mi East Interchange # 131	Underpass	14' 6"	No
36-200-110	36-200-111	County Road		I-90 MRM 139.30 4 mi West Interchange # 143	Underpass	14' 11"	No
36-270-110	36-270-111	County Road		I-90 MRM 146.26 3 mi East Interchange # 143	Underpass	14' 3"	No
36-360-098	36-360-099	County Road		I-90 MRM 155.04 3 mi East Interchange # 152	Underpass	15' 0"	No
36-400-102	36-400-103	County Road		I-90 MRM 159.42 3.6 mi West Interchange # 163	Underpass	13' 10"	No
36-450-106	36-450-105	County Road		I-90 MRM 164.43 1.4 mi East Interchange # 163	Underpass	14' 2"	No
36-480-090	36-480-091	County Road		I-90 MRM 167.83 2.5 mi SW Interchange # 170	Underpass	16' 0"	No
36-520-067	36-520-068	County Road		I-90 MRM 172.50 Interchange # 172 (Stamford)	Interchange	14' 4"	No
38-060-186	38-060-185	County Road		I-90 MRM 180.48 3 mi East Interchange # 177	Underpass	14' 4"	No
38-088-194	38-088-193	County Road		I-90 MRM 183.48 Interchange # 183 (Okaton)	Interchange	16' 2"	No
38-110-195	38-110-196	County Road		I-90 MRM 185.69 2.2 mi East Interchange # 183	Underpass	14' 5"	No
38-200-190	38-200-191	County Road		I-90 MRM 194.81 2.2 mi East Interchange # 192	Underpass	13' 4"	No
38-240-178	38-240-179	County Road		I-90 MRM 199.16 2 mi West Interchange # 201	Underpass	14' 10"	No
38-260-179	38-260-178	County Road		I-90 MRM 201.13 Interchange # 201 (Draper)	Interchange	15' 1"	No
38-290-178	38-290-179	County Road		I-90 MRM 204.13 3 mi East Interchange # 201	Underpass	14' 2"	No

Secondary Structure	Structure Controlling Height	Hwy Number	MRM	Location	Structure Type	Maximum Permit Clearance	By-pass ?
38-330-178	38-330-179	County Road		I-90 MRM 208.11 Interchange # 208	Interchange	14' 3"	No
43-040-196	43-040-195	County Road		I-90 MRM 214.15 Interchange # 214 (Vivian)	Interchange	14' 10"	No
43-063-195	43-063-196	County Road		I-90 MRM 216.39 1.2 mi East Interchange # 214	Underpass	13' 6"	No
43-100-201	43-100-202	County Road		I-90 MRM 220.31 Interchange # 220	Interchange	14' 2"	No
43-130-206	43-130-205	County Road		I-90 MRM 223.39 2 mi West Interchange # 225	Underpass	14' 0"	No
43-150-205	43-150-206	County Road		I-90 MRM 225.38 Interchange # 225 (Presho)	Interchange	14' 0"	No
43-180-205	43-180-206	County Road		I-90 MRM 228.39 2 mi East Interchange # 226	Underpass	14' 1"	No
43-200-206	43-200-205	County Road		I-90 MRM 230.39 4 mi East Interchange # 226	Underpass	14' 2"	No
43-220-206	43-220-205	County Road		I-90 MRM 232.32 3.1 mi West Interchange # 235	Underpass	14' 3"	No
43-290-219	43-290-220	County Road		I-90 MRM 239.66 2.2 mi West Interchange # 241	Underpass	14' 8"	No
43-313-220	43-313-221	County Road		I-90 MRM 241.90 Interchange # 241 (Lyman)	Interchange	14' 8"	No
43-340-224	43-340-225	County Road		I-90 MRM 244.75 3 mi East Interchange # 241	Underpass	14' 1"	No
43-428-240	43-428-241	Frontage Road		I-90 MRM 253.90 2.8 mi East Interchange # 251	Underpass	13' 3"	No
43-466-261	43-466-262	Frontage Road		I-90 MRM 258.37 2.1 mi West Interchange # 260	Underpass	13' 0"	No
43-475-267	43-475-268	County Road		I-90 MRM 259.52 1 mi West Interchange # 260	Underpass	14' 3"	No
08-065-095	08-066-095	City Street		I-90 MRM 263.53 Inter. # 263 (Chamberlain)	Interchange	16' 9"	No

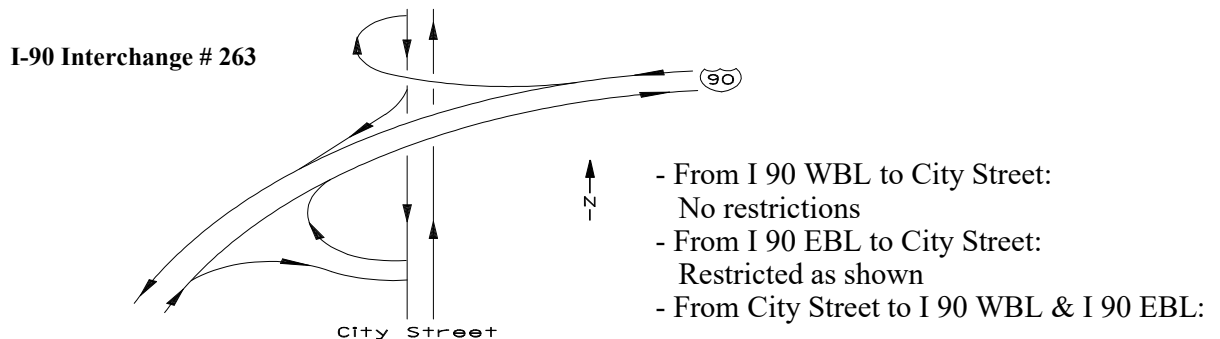

Secondary Structure	Structure Controlling Height	Hwy Number	MRM	Location	Structure Type	Maximum Permit Clearance	By-pass ?
08-200-125	08-200-126	County Road		I-90 MRM 278.16 5.5 mi East Interchange # 272	Underpass	14' 10"	No
08-230-130	08-230-131	County Road		I-90 MRM 281.13 3 mi West Interchange # 284	Underpass	17' 1"	No
18-150-107	18-150-108	S. Rowley Street		I-90 MRM 331.43 1 mi East Interchange # 330	Underpass	14' 11"	No
31-070-123	31-070-122	County Road		I-90 MRM 341.98 2 mi West Interchange # 344	Underpass	14' 2"	No
44-130-126	44-130-125	County Road		I-90 MRM 366.06 2 mi East Interchange # 364	Underpass	16' 8"	No
44-230-125	44-230-126	County Road		I-90 MRM 376.03 2 mi East Interchange # 374	Underpass	13' 10"	No
50-140-166	50-140-165	County Road		I-90 MRM 392.47 2.2 mi East Interchange # 390	Underpass	15' 0"	No
50-193-164	50-193-165	County Road		I-90 MRM 397.86 1.3 mi East Interchange # 396	Underpass	12' 8"	No
Miscellaneous Roads Under I-190							
	52-409-294	North Street		I-190 MRM 0.43 1.2 mi south of I-90 Rapid City	Underpass	17' 1"	No
Miscellaneous Roads Under I-229							
	50-187-240	57th St. N & SBL		I-229 MRM 1.66 Sioux Falls, Tunnel	Underpass	16' 5"	No
50-210-230	50-211-230	Cliff Avenue		I-229 MRM 4.16 Sioux Falls	Underpass	15' 9"	No
50-217-217	50-218-217	Southeastern Ave.		I-229 MRM 5.70 Sioux Falls	Underpass	23' 8"	No
50-218-197	50-219-197	Rice Street		I-229 MRM 7.84 Sioux Falls	Underpass	21' 0"	No
Miscellaneous Roads Under US 16T							
	52-430-314	St. Joseph Street		SD 16T MRM 69.38 Rapid City	Underpass	15' 10"	No
Miscellaneous Roads Under US 18							
	24-116-116	County Road		US 18 MRM 12.57 NE edge of Edgemont	Underpass	24' 11"	No

Secondary Structure	Structure Controlling Height	Hwy Number	MRM	Location	Structure Type	Maximum Permit Clearance	By-pass ?
	24-291-032	City Street		US 18 MRM 39.60 Hot Springs 0.2 West Jct US 385	Underpass	12' 7"	No
Miscellaneous Roads Under US 281							
		This section of US 281 was transferred to the City of Aberdeen and is no longer part of the State Highway system					
Miscellaneous Roads Under SD 42E							
	50-205-209	Third Avenue		SD 42E MRM 366.74 Sioux Falls 0.6 East Jct SD 115	Underpass	16' 9"	No
Miscellaneous Roads Under SD 37							
	18-141-093	Fourth Avenue		SD 37 MRM 74.50 Mitchell 0.8 North Jct I-90 Loop E	Underpass	22' 10"	No
Miscellaneous Structures							
	0029007700CS1L	I-29 S		Exit 77 41st Street Interchange I-29S Off-Ramp	Sign Bridge	20' 7"	No
	0029007700SB2R	I-29		41st Street in Sioux Falls in advance of I-29	Sign Bridge	17' 10"	No
	0029007900CS1R	I-29 N		Exit 79 Ramp 12th Street Interchange I-29N Off-Ramp	Sign Bridge	19' 7"	No
	0029007900CS2L	I-29 S		Exit 79 Ramp 12th Street Interchange I-29S Off-Ramp	Sign Bridge	19' 9"	No
	0029008100CS1L	I-29		Exit 81 on Russell Street in advance of I-29	Sign Bridge	17' 1"	No
	0029008100CS2R	I-29		Exit 81 on Russell Street in advance of I-29	Sign Bridge	17' 5"	No
	0029008100CS3R	I-29		Exit 81 on Russell Street in advance of I-29	Sign Bridge	17' 11"	No
	0090L33340CS1R	I-90L		Havens Ave. Mitchell .1 mile East of Sanborn Blvd.	Canitilever Hwy Sign	17' 6"	No
	0090L33360CS1L	I-90L		Havens Ave. Mitchell .1 mile West of Sanborn Blvd.	Canitilever Hwy Sign	17' 3"	No
	0090039500CS1R	I-90 E		Exit 395 Marion Road Interchange I-90E Off-Ramp	Cantilever Hwy Sign	20' 1"	No
	0090039900CS1R	I-90 E		Exit 399 Cliff Ave. Interchange I-90E Off-Ramp	Cantilever Hwy Sign	17' 9"	No
	0090039900CS2L	I-90 W		Exit 399 Cliff Ave. Interchange I-90W Off-Ramp	Cantilever Hwy Sign	18' 1"	No

Secondary Structure	Structure Controlling Height	Hwy Number	MRM	Location	Structure Type	Maximum Permit Clearance	By-pass ?
	0229000100SB2L	I-229		Exit 1 on Louise Ave. - .25 miles North of I-229	Sign Bridge	19' 4"	No
	0229000100SB1R	I-229		Exit 1 on Louise Ave. - .05 miles North of I-229	Sign Bridge	18' 3"	No
	0229000100SB3L	I-229 S		Exit 1 Off Ramp Louise Ave. Interchange I-229S Off-Ramp	Sign Bridge	19' 0"	No